



(19) **United States**

(12) **Patent Application Publication**
KIM et al.

(10) **Pub. No.: US 2019/0288229 A1**
(43) **Pub. Date: Sep. 19, 2019**

(54) **ELECTROLUMINESCENT DEVICE,
MANUFACTURING METHOD THEREOF,
AND DISPLAY DEVICE COMPRISING THE
SAME**

(71) Applicant: **SAMSUNG ELECTRONICS CO.,
LTD.**, Suwon-si (KR)

(72) Inventors: **Sung Woo KIM**, Hwaseong-si (KR);
Chan Su KIM, Seoul (KR); **Tae Ho
KIM**, Seongnam-si (KR); **Kun Su
PARK**, Seongnam-si (KR); **Eun Joo
JANG**, Suwon-si (KR); **Jin A KIM**,
Suwon-si (KR); **Tae Hyung KIM**,
Seoul (KR); **Jeong Hee LEE**,
Seongnam-si (KR)

(21) Appl. No.: **16/351,654**

(22) Filed: **Mar. 13, 2019**

(30) **Foreign Application Priority Data**

Mar. 14, 2018 (KR) 10-2018-0029942
Mar. 12, 2019 (KR) 10-2019-0028358

Publication Classification

(51) **Int. Cl.**
H01L 51/50 (2006.01)
H01L 51/00 (2006.01)
H01L 51/42 (2006.01)
(52) **U.S. Cl.**
CPC **H01L 51/5012** (2013.01); **H01L 51/0062**
(2013.01); **H01L 51/4213** (2013.01); **H01L**
51/5056 (2013.01); **H01L 51/5072** (2013.01)

(57) **ABSTRACT**

An electroluminescent device, a method of manufacturing the same, and a display device including the same. The electroluminescent device includes a first electrode and a second electrode facing each other; an emission layer disposed between the first electrode and the second electrode, the emission layer including light emitting particles; an electron transport layer disposed between the first electrode and the emission layer; and a hole transport layer disposed between the second electrode and the emission layer, wherein the electron transport layer includes inorganic oxide particles and a metal-organic compound, the metal-organic compound or a thermal decomposition product of the metal-organic compound being soluble a non-polar solvent.

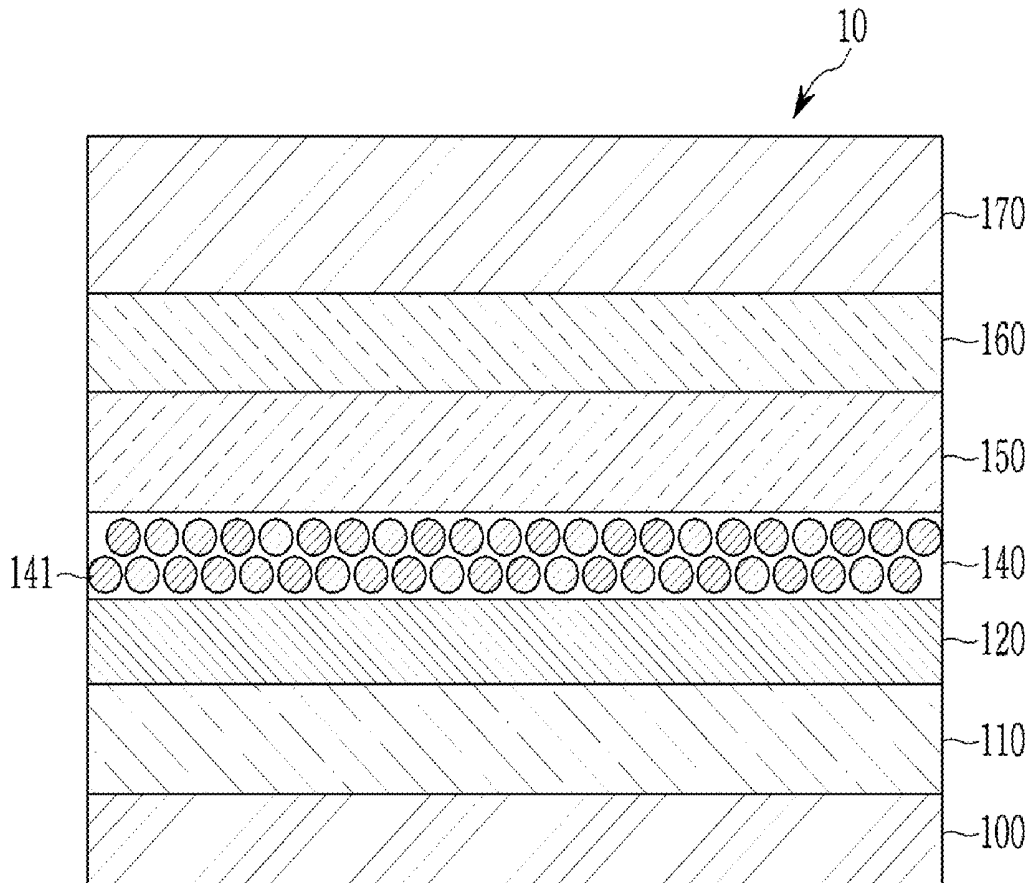

FIG. 1

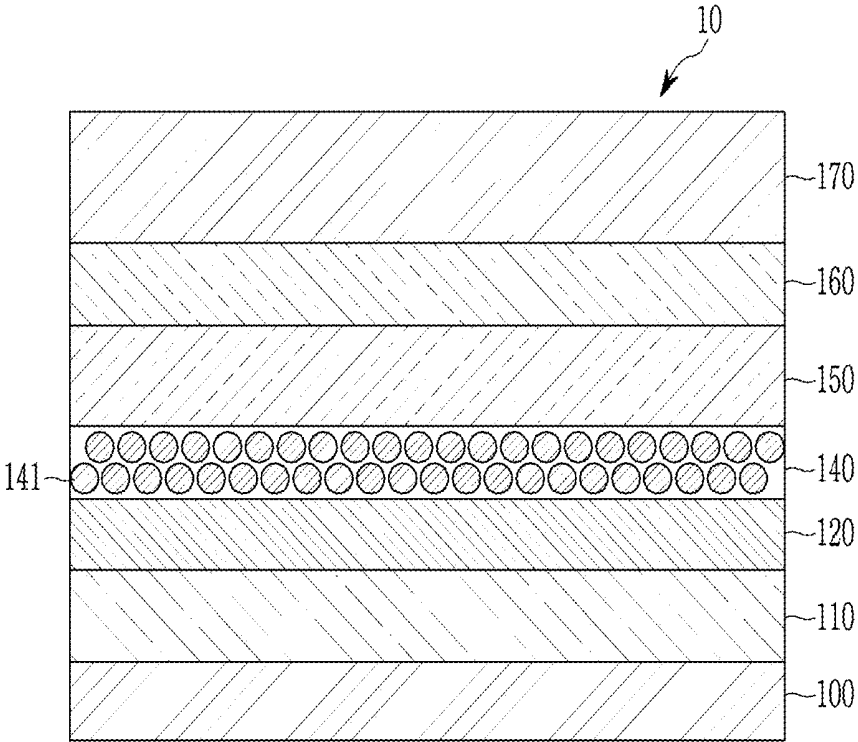

FIG. 2

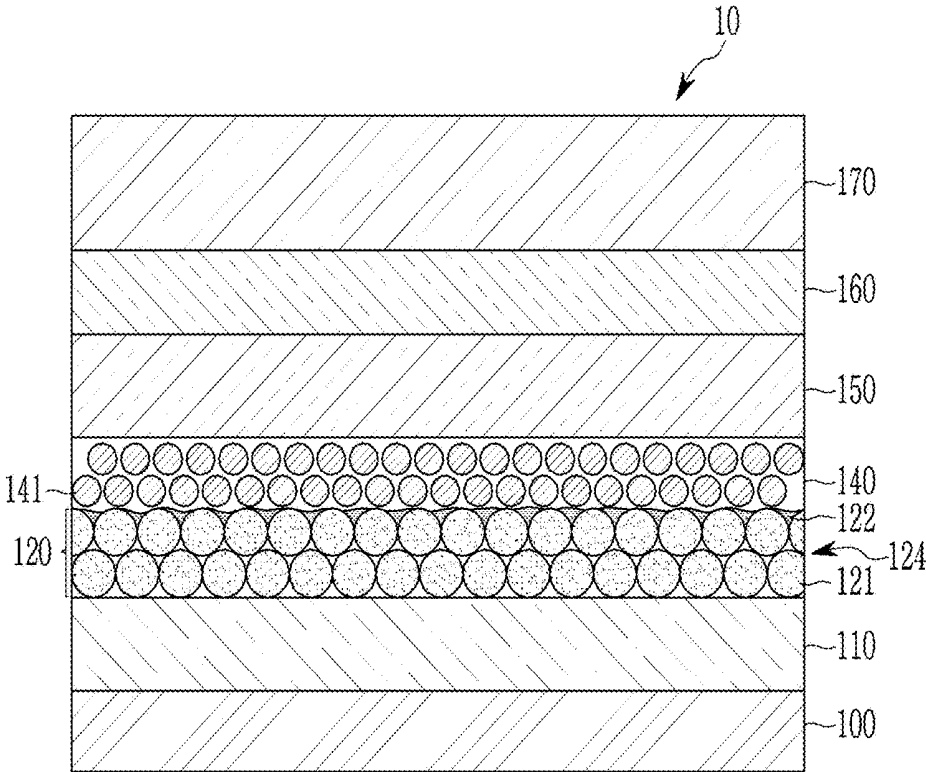

FIG. 3

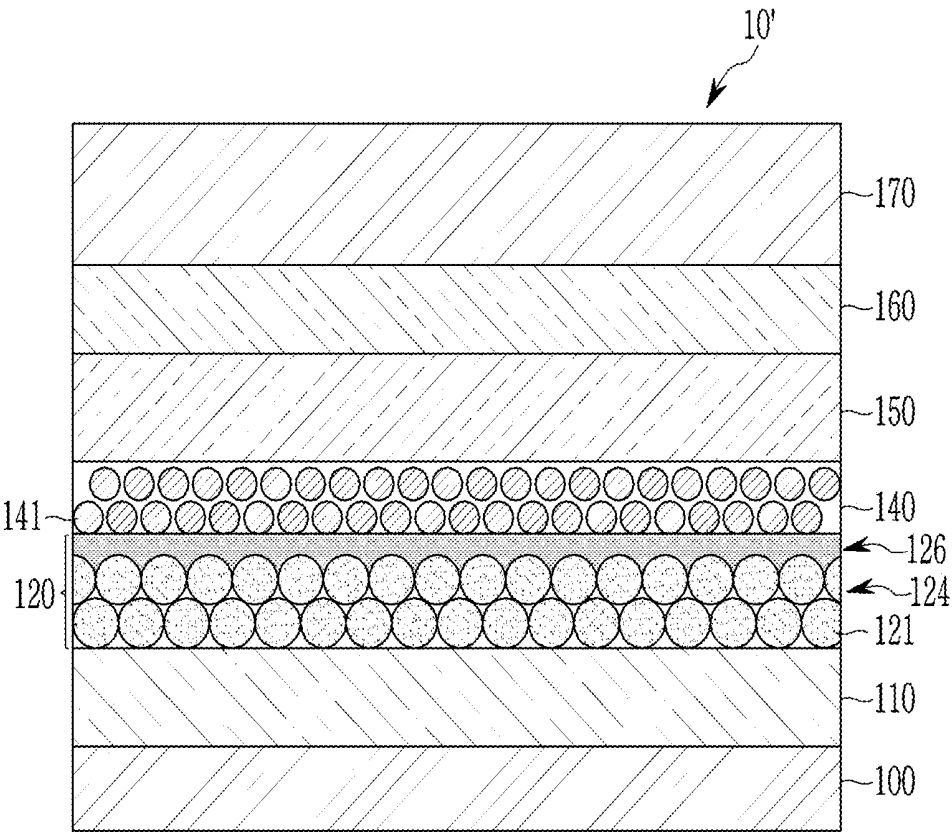

FIG. 4

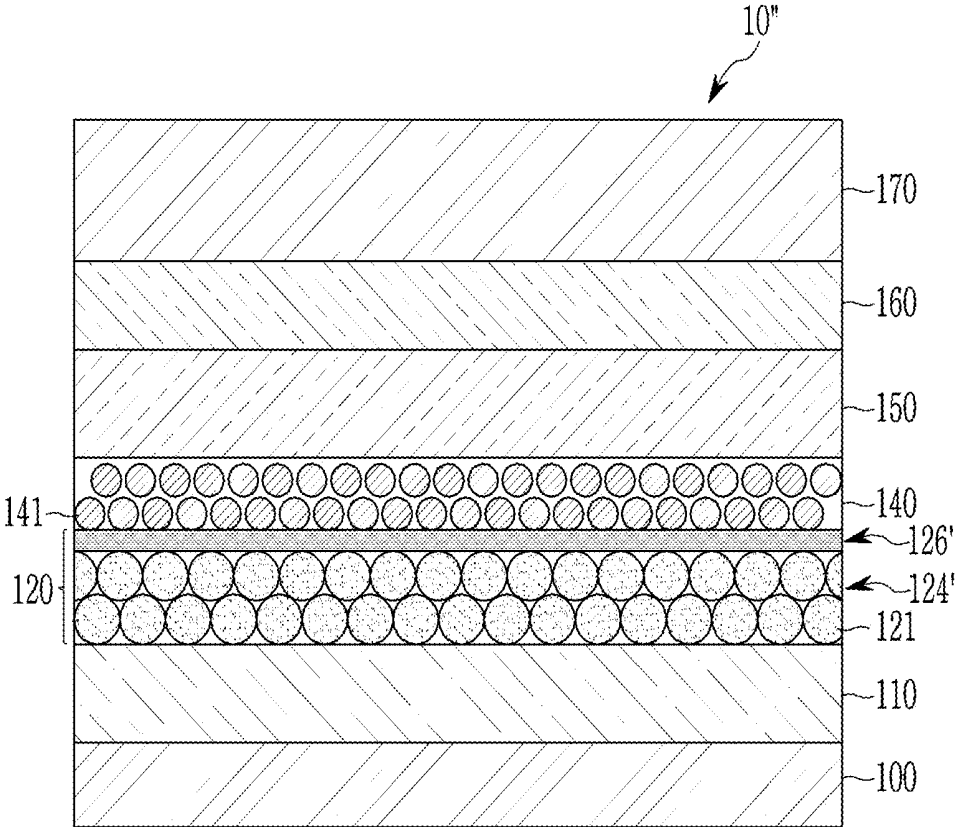

FIG. 5

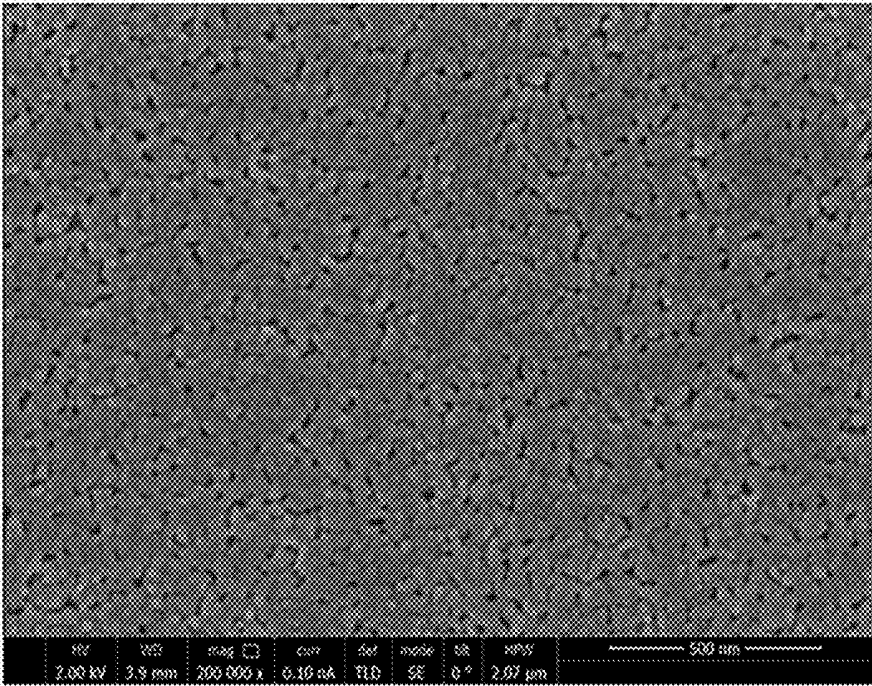

FIG. 6

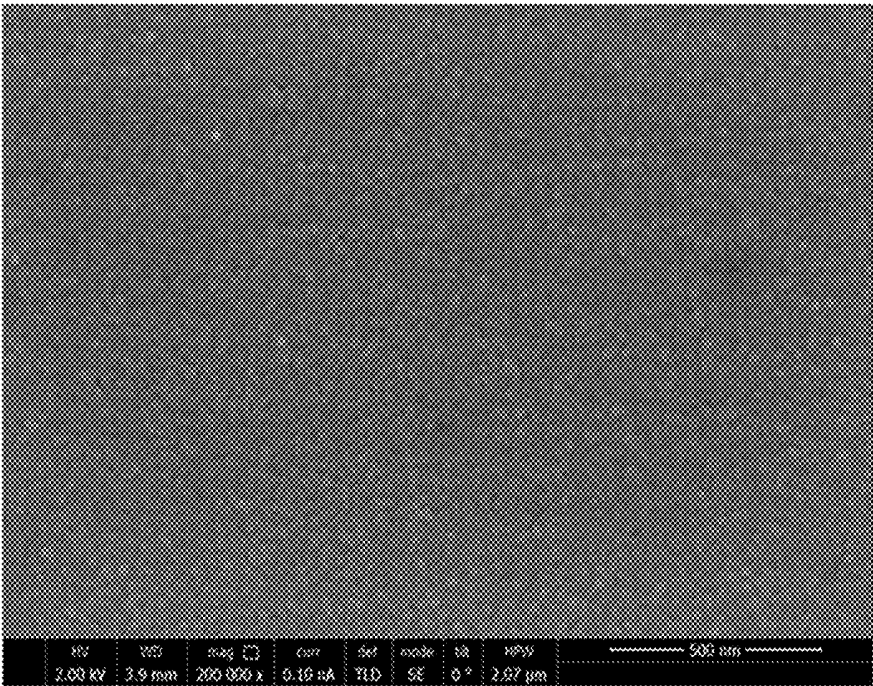

FIG. 7

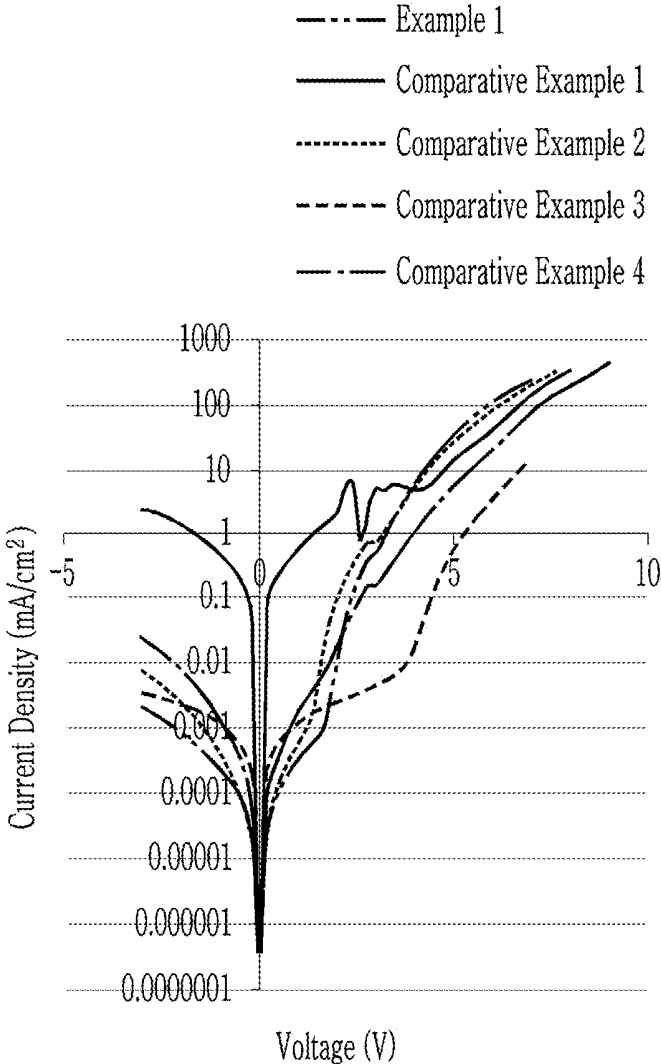

FIG. 8

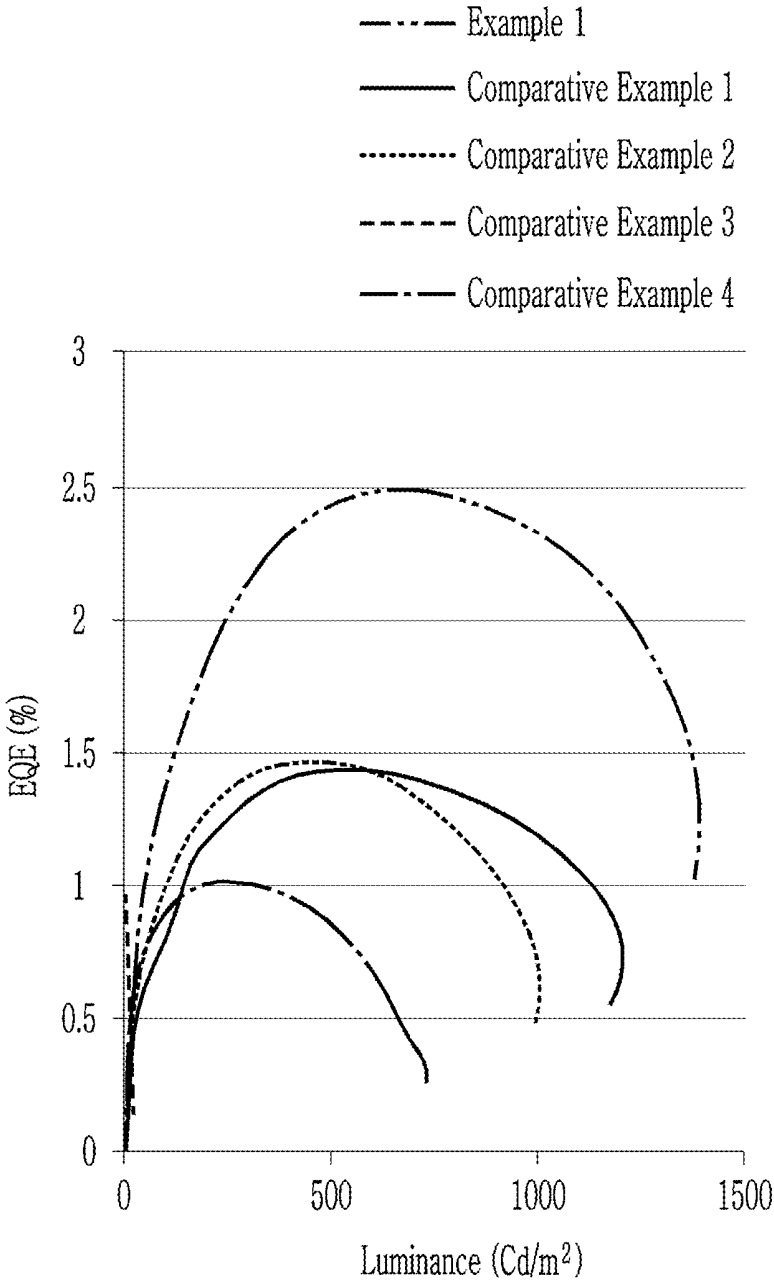

FIG. 9

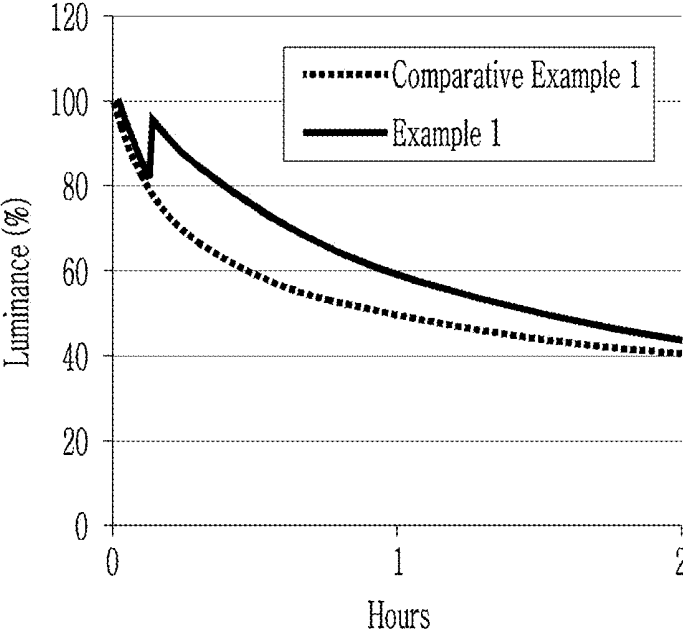
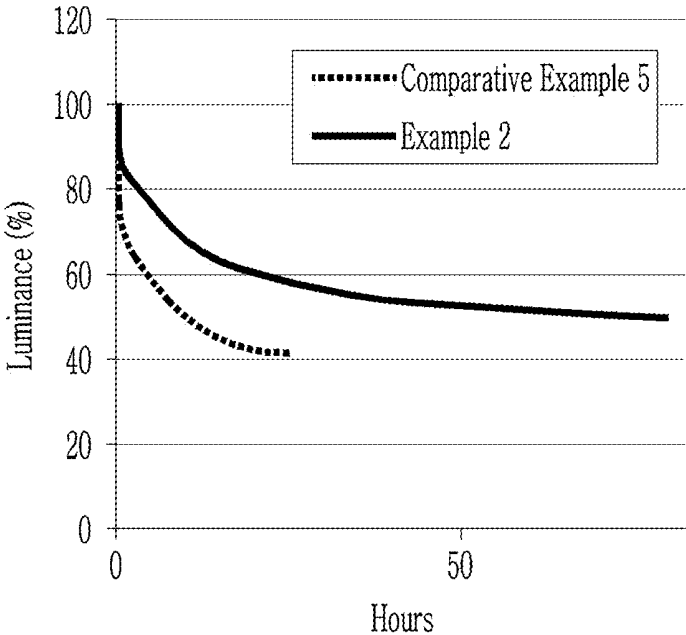

FIG. 10



**ELECTROLUMINESCENT DEVICE,
MANUFACTURING METHOD THEREOF,
AND DISPLAY DEVICE COMPRISING THE
SAME**

**CROSS-REFERENCE TO RELATED
APPLICATION**

[0001] This application claims priority to and the benefit of Korean Patent Application No. 10-2018-0029942 filed in the Korean Intellectual Property Office on Mar. 14, 2018, and Korean Patent Application No. 10-2019-0028358 filed in the Korean Intellectual Property Office on Mar. 12, 2019, and all the benefits accruing therefrom under 35 U.S.C. § 119, the entire content of which is incorporated herein by reference.

BACKGROUND

1. Field

[0002] The present invention relates to an electroluminescent device, manufacturing method thereof, and a display device including the same.

2. Description of the Related Art

[0003] Quantum dots are a nanocrystal semiconductor material having a diameter of several to several hundreds of nanometers (nm), which exhibits quantum confinement effects. Quantum dots generate stronger, e.g., brighter, light in a narrow wavelength region than phosphor. Quantum dots emit light while the excited electrons are transitioned from a conduction band to a valence band and wavelengths are changed depending upon a particle size of the quantum dot. As quantum dots emit shorter wavelength light with decreasing particle size, quantum dots may provide light in a desirable wavelength region by adjusting the sizes of the quantum dots.

[0004] In other words, the emission layer including quantum dots and the various electronic devices including the same may reduce production costs, compared with the organic light emitting diode using the emission layer including phosphorescence and/or phosphor material, and the desirable color may be emitted by changing sizes of quantum dots, without use of other organic materials in the emission layer for emitting other color lights.

[0005] Luminous efficiency of the emission layer including quantum dots is determined by quantum efficiency of the quantum dots, a balance of charge carriers, light extraction efficiency, leakage current, and the like. That is, in order to improve the luminous efficiency of the emission layer, methods, such as adjusting excitons to be confined to the emission layer, adjusting holes and electrons to be smoothly transported to the quantum dots, or preventing leakage currents, may be used.

SUMMARY

[0006] An electroluminescent device having improved device characteristics by decreasing a leakage current and a display device including the same are provided.

[0007] According to an embodiment, an electroluminescent device includes a first electrode and a second electrode facing each other; an emission layer disposed between the first electrode and the second electrode, the emission layer including light emitting particles; an electron transport layer

disposed between the first electrode and the emission layer; and a hole transport layer disposed between the second electrode and the emission layer, wherein the electron transport layer includes inorganic oxide particles and a metal-organic compound, the metal-organic compound or a thermal decomposition product of the metal-organic compound being soluble in a non-polar solvent.

[0008] The metal-organic compound may include Zn, Ti, Sn, W, Ta, Mg, Ga, Na, Cu, Ag, or a combination thereof.

[0009] The metal-organic compound may include an oleate compound, an amine compound, or a combination thereof.

[0010] The non-polar solvent may include a C₆ to C₂₀ linear, branched, or cyclic aliphatic hydrocarbon, a C₆ to C₂₀ aromatic hydrocarbon, methylene chloride, ethyl acetate, or a combination thereof.

[0011] The inorganic oxide particles may include zinc, titanium, zirconium, tin, tungsten, tantalum, magnesium, gallium, sodium, copper, silver, or a combination thereof.

[0012] The inorganic oxide particles may be dispersible in a polar solvent.

[0013] A surface of the electron transport layer facing the emission layer may include a first portion in which the inorganic oxide particles are disposed and a second portion in which the metal-organic compound or the thermal decomposition product of the metal-organic compound is between neighboring inorganic oxide particles.

[0014] The electron transport layer may include a first layer including the inorganic oxide particles and a second layer including the metal-organic compound or the thermal decomposition product of the metal-organic compound.

[0015] The second layer may be disposed between the first layer and the emission layer.

[0016] The first layer may include a cluster layer including the inorganic oxide particles.

[0017] A surface of the first layer facing the second layer may include the metal-organic compound or the thermal decomposition product of the metal-organic compound.

[0018] The first layer may include an organic matrix filled in between neighboring inorganic oxide particles and the organic matrix may include an organic material that is different from the metal-organic compound or the thermal decomposition product of the metal-organic compound.

[0019] An average thickness of the second layer may be less than an average thickness of the first layer.

[0020] The inorganic oxide particles may include metal oxide particles, and a metal in the metal oxide particles and a metal in the metal-organic compound are the same.

[0021] An average thickness of the electron transport layer may be about 20 nanometers (nm) to about 60 nm.

[0022] The light emitting particles may include quantum dots.

[0023] The light emitting particles may have a core-shell structure.

[0024] The light emitting particles may include a Group II-VI compound that does not include Cd, a Group III-V compound, a Group IV-VI compound, a Group IV element or compound, a Group I-III-VI compound, a Group I-II-IV-VI compound that does not include Cd, or a combination thereof.

[0025] A hydrophobic organic ligand may be attached to a surface of the light emitting particles.

[0026] On the other hand, a display device including the electroluminescent device according to an embodiment is provided.

[0027] An electroluminescent device having improved device characteristics by decreasing the leakage current may be provided.

[0028] In addition, as described above, a display device including the electroluminescent device having improved device characteristics is provided.

BRIEF DESCRIPTION OF THE DRAWINGS

[0029] The above and other advantages and features of this disclosure will become more apparent by describing in further detail exemplary embodiments thereof with reference to the accompanying drawings, in which:

[0030] FIG. 1 is a schematic cross-sectional view of an electroluminescent device according to an embodiment,

[0031] FIGS. 2 to 4 are cross-sectional views illustrating various positional relationships between inorganic oxide particles, a metal-organic compound, and a thermal decomposition product thereof in an electron transport layer of an electroluminescent device according to an embodiment,

[0032] FIG. 5 shows a scanning electron microscopic (SEM) image of the surface of the ZnO cluster layer of Comparative Example 1,

[0033] FIG. 6 is a SEM image of the surface of a zinc-oleate or a thermal decomposition product layer thereof formed on the ZnO cluster layer of Example 1,

[0034] FIG. 7 is a graph of current density (milliamperes per square centimeter (mA/cm²)) versus voltage (volts (V)) of the electroluminescent devices of Example 1 and Comparative Examples 1 to 4,

[0035] FIG. 8 is a graph of external quantum efficiency (EQE (percent (%))) versus luminescence (candela per square meter (Cd/m²)) of the electroluminescent devices of Example 1 and Comparative Examples 1 to 4,

[0036] FIG. 9 is a graph of luminance (%) versus hours showing life-span characteristics of the electroluminescent devices of Example 1 and Comparative Example 1, and

[0037] FIG. 10 is a graph of luminance (%) versus hours showing life-span characteristics of the electroluminescent devices of Example 2 and Comparative Example 5.

DETAILED DESCRIPTION

[0038] Hereinafter, example embodiments will be described in detail so that a person skilled in the art would understand the same. This disclosure may, however, be embodied in many different forms and is not construed as limited to the example embodiments set forth herein.

[0039] In the drawings, the thickness of layers, films, panels, regions, etc., are exaggerated for clarity. Like reference numerals designate like elements throughout the specification. It will be understood that when an element such as a layer, film, region, or substrate is referred to as being “on” another element, it can be directly on the other element or intervening elements may also be present. In contrast, when an element is referred to as being “directly on” another element, there are no intervening elements present.

[0040] It will be understood that, although the terms “first,” “second,” “third” etc. may be used herein to describe various elements, components, regions, layers and/or sections, these elements, components, regions, layers and/or sections should not be limited by these terms. These terms

are only used to distinguish one element, component, region, layer or section from another element, component, region, layer or section. Thus, “a first element,” “component,” “region,” “layer” or “section” discussed below could be termed a second element, component, region, layer or section without departing from the teachings herein.

[0041] The terminology used herein is for the purpose of describing particular embodiments only and is not intended to be limiting. As used herein, the singular forms “a,” “an,” and “the” are intended to include the plural forms, including “at least one,” unless the content clearly indicates otherwise. “At least one” is not to be construed as limiting “a” or “an.” “Or” means “and/or.” As used herein, the term “and/or” includes any and all combinations of one or more of the associated listed items. It will be further understood that the terms “comprises” and/or “comprising,” or “includes” and/or “including” when used in this specification, specify the presence of stated features, regions, integers, steps, operations, elements, and/or components, but do not preclude the presence or addition of one or more other features, regions, integers, steps, operations, elements, components, and/or groups thereof.

[0042] Furthermore, relative terms, such as “upper,” may be used herein to describe one element’s relationship to another element as illustrated in the Figures. It will be understood that relative terms are intended to encompass different orientations of the device in addition to the orientation depicted in the Figures. For example, if the device in one of the figures is turned over, elements described as being on the “lower” side of other elements would then be oriented on “upper” sides of the other elements. The exemplary term “lower,” can therefore, encompass both an orientation of “lower” and “upper,” depending on the particular orientation of the figure.

[0043] “About” as used herein is inclusive of the stated value and means within an acceptable range of deviation for the particular value as determined by one of ordinary skill in the art, considering the measurement in question and the error associated with measurement of the particular quantity (i.e., the limitations of the measurement system). For example, “about” can mean within one or more standard deviations, or within $\pm 30\%$, 20%, 10% or 5% of the stated value.

[0044] Unless otherwise defined, all terms (including technical and scientific terms) used herein have the same meaning as commonly understood by one of ordinary skill in the art to which this disclosure belongs. It will be further understood that terms, such as those defined in commonly used dictionaries, should be interpreted as having a meaning that is consistent with their meaning in the context of the relevant art and the present disclosure, and will not be interpreted in an idealized or overly formal sense unless expressly so defined herein.

[0045] Exemplary embodiments are described herein with reference to cross section illustrations that are schematic illustrations of idealized embodiments. As such, variations from the shapes of the illustrations as a result, for example, of manufacturing techniques and/or tolerances, are to be expected. Thus, embodiments described herein should not be construed as limited to the particular shapes of regions as illustrated herein but are to include deviations in shapes that result, for example, from manufacturing. For example, a region illustrated or described as flat may, typically, have rough and/or nonlinear features. Moreover, sharp angles that

are illustrated may be rounded. Thus, the regions illustrated in the figures are schematic in nature and their shapes are not intended to illustrate the precise shape of a region and are not intended to limit the scope of the present claims.

[0046] As used herein, “group” may refer to a group of Periodic Table.

[0047] As used herein, “Group II” may refer to Group IIA and Group IIB, and examples of Group II metal may be Cd, Zn, Hg, and Mg, but are not limited thereto.

[0048] As used herein, examples of “Group II metal that does not include Cd” may refer to a Group II metal except Cd, for example, Zn, Hg, Mg, etc.

[0049] As used herein, “Group III” may refer to Group IIIA and Group IIIB, and examples of Group III metal may be Al, In, Ga, and Tl, but are not limited thereto.

[0050] As used herein, “Group IV” may refer to Group IVA and Group IVB, and examples of a Group IV metal may be Si, Ge, and Sn, but are not limited thereto. As used herein, the term “metal” may include a semi-metal such as Si.

[0051] As used herein, “Group I” may refer to Group IA and Group IB, and examples may include Li, Na, K, Rb, and Cs, but are not limited thereto.

[0052] As used herein, “Group V” may refer to Group VA, and examples may include nitrogen, phosphorus, arsenic, antimony, and bismuth, but are not limited thereto.

[0053] As used herein, “Group VI” may refer to Group VIA, and examples may include sulfur, selenium, and tellurium, but are not limited thereto.

[0054] As used herein, “aliphatic” means a saturated or unsaturated linear or branched hydrocarbon group. An aliphatic group may be an alkyl, alkenyl, or alkynyl group, for example.

[0055] As used herein, an “amine” has the general formula NRR , wherein each R is independently hydrogen, a C1-030 alkyl group, a C3-C8 cycloalkyl group, a C2-C30 alkenyl group, a C2-C30 alkynyl group, or a C6-C30 aryl group, each of which may be substituted or unsubstituted.

[0056] As used herein, “aromatic” means an organic compound or group comprising at least one unsaturated cyclic group having delocalized pi electrons. The term encompasses both hydrocarbon aromatic compounds and heteroaromatic compounds.

[0057] In an embodiment, for particle diameters of particles, although the particle diameters may be quantitated by a measurement to show an average size of a group, the method may include a mode diameter showing the maximum value of the distribution, a median diameter corresponding to the center value of integral distribution curve, a variety of average diameters (numeral average, length average, area average, mass average, volume average, etc.), and the like. Unless particularly mentioned otherwise, “average particle diameters” means numeral average diameters in the present disclosure, and the average particle diameter is obtained by measuring D50 (particle diameters at a position of distribution rate of 50%).

[0058] In an embodiment, “solubility” indicates property that a solute is well dissolved in a particular solvent. In an embodiment, when a solute is well dissolved in a non-polar solvent, the corresponding solute may be expressed as having a solubility regarding, e.g., in, the non-polar solvent, while a solute is well dissolved in a polar solvent, the corresponding solute may be expressed as having a solubility regarding, e.g., in, the polar solvent.

[0059] Unless otherwise described in an embodiment, a thickness of each constituent element may refer to “an average thickness.”

[0060] The “average thickness” of each constituent element is calculated by extracting arbitrary 5 to 10 points from a scanning electron microscopic (SEM) cross-sectional image of each constituent element, measuring thicknesses, and calculating an arithmetic average of the measured thicknesses.

[0061] FIG. 1 is a schematic cross-sectional view of an electroluminescent device according to an embodiment and FIGS. 2 to 4 are cross-sectional views illustrating various positional relationships between inorganic oxide particles, a metal-organic compound, and a thermal decomposition product thereof in an electron transport layer of an electroluminescent device according to an embodiment.

[0062] An electroluminescent device 10 according to an embodiment includes a first electrode 110 and a second electrode 170 facing each other, an emission layer 141 disposed between the first electrode 110 and the second electrode 170 and including light emitting particles 141; an electron transport layer 120 disposed between the first electrode 110 and the emission layer 140; and a hole transport layer 150 disposed between the second electrode 170 and the emission layer 140, and a hole injection layer 160 that is disposed between the hole transport layer 150 and the second electrode 170 and may be omitted in consideration of a relationship of each constituent element.

[0063] The electroluminescent device 10 may have a laminate structure where the electron transport layer 120, the emission layer 140, the hole transport layer 150, and the hole injection layer 160 are disposed between the first electrode 110 and the second electrode 170 facing each other.

[0064] The electroluminescent device 10 according to an embodiment supplies current to the emission layer 140 through the first electrode 110 and the second electrode 170 and causes electroluminescence of the light emitting particles 141 to generate light. The electroluminescent device 10 may generate light in various wavelength regions according to materials, sizes, or fine structures of the light emitting particles 141 of the emission layer 140.

[0065] In an embodiment, the first electrode 110 and the second electrode 170 may be respectively connected to a driving power source and may function to supply current to the emission layer 140. One of the first electrode 110 and the second electrode 170 may be an anode and the other may be a cathode. In an embodiment, the first electrode 110 may be a cathode and the second electrode 170 may be an anode.

[0066] At least one of the first electrode 110 and the second electrode 170 may include a material having light transmittance in at least visible light wavelength region but is not limited thereto. The first electrode 110 may include a material having light transmittance in an infrared or ultraviolet (UV) wavelength region. For example, the first electrode 110 may include an optically transparent material. For example, the second electrode 170 may include an optically transparent material. For example, the first electrode 110 and the second electrode 170 may include an optically transparent material.

[0067] In an embodiment, the optically transparent material may include, for example, molybdenum oxide, tungsten oxide, vanadium oxide, rhenium oxide, niobium oxide, tantalum oxide, titanium oxide, zinc oxide, nickel oxide, copper oxide, cobalt oxide, manganese oxide, chromium

oxide, indium oxide, tin oxide, indium tin oxide, indium zinc oxide, or a combination thereof, or silver (Ag), aluminum (Al), copper (Cu), gold (Au), an alloy thereof, or a combination thereof.

[0068] In an embodiment, one of the first electrode **110** and the second electrode **170** may include molybdenum oxide, tungsten oxide, vanadium oxide, rhenium oxide, niobium oxide, tantalum oxide, titanium oxide, zinc oxide, nickel oxide, copper oxide, cobalt oxide, manganese oxide, chromium oxide, indium oxide, tin oxide, indium tin oxide, indium zinc oxide, or a combination thereof and the other of the first electrode **110** and the second electrode **170** may include silver (Ag), aluminum (Al), copper (Cu), gold (Au), an alloy thereof, or a combination thereof. For example, the first electrode **110** may include molybdenum oxide, tungsten oxide, vanadium oxide, rhenium oxide, niobium oxide, tantalum oxide, titanium oxide, zinc oxide, nickel oxide, copper oxide, cobalt oxide, manganese oxide, chromium oxide, indium oxide, tin oxide, indium tin oxide, indium zinc oxide, or a combination thereof and the second electrode **170** may include silver (Ag), aluminum (Al), copper (Cu), gold (Au), an alloy thereof, or a combination thereof.

[0069] However, the first electrode **110** and/or the second electrode **170** according to an embodiment are not necessarily limited thereto but may include a material further having light transmittance with respect to light in an infrared or ultraviolet (UV) wavelength region or a semi-permeable material selectively transmitting light in a particular wavelength region and may conduct a function of reflecting light in a visible light wavelength region.

[0070] Each of the first electrode **110** and the second electrode **170** may be formed by depositing a material for forming an electrode on the substrate **100** or an organic layer by a method such as sputtering or deposition.

[0071] Meanwhile, in an embodiment, the first electrode **110** may be disposed on the substrate **100** as shown in FIG. 1. The substrate **100** may be a transparent insulating substrate or may include a ductile material. The substrate **100** may include glass or a polymer material, and the polymer material may have, for example, a glass transition temperature (T_g) of greater than or equal to about 150°C . For example, the substrate **100** may include a COC (cycloolefin copolymer) or COP (cycloolefin polymer) based material.

[0072] In an embodiment, the substrate **100** may support the electron transport layer **120**, the emission layer **140**, the hole transport layer **150**, and the hole injection layer **160** disposed between the first electrode **110** and the second electrode **170**.

[0073] However, the substrate **100** of the electroluminescent device **10** according to an embodiment may not be disposed under the first electrode **110**, but the substrate **100** of the electroluminescent device **10** may be disposed on the second electrode **170** or may be omitted, as desired.

[0074] In an embodiment, the electron transport layer **120** is disposed between the first electrode **110** and the emission layer **140** and transports charges from the first electrode **110** into the emission layer **140**. The charges may be electrons.

[0075] In an embodiment, an average thickness of the electron transport layer **120** may be variously changed in consideration of a charge carrier balance of the hole transport layer **150**, the hole injection layer **160**, the emission layer **140**, or a combination thereof in the device, but may be, for example, greater than or equal to about 20 nm, greater than or equal to about 25 nm, greater than or equal to about

30 nm, greater than or equal to about 35 nm, or greater than or equal to about 40 nm, and, for example, less than or equal to about 100 nm, less than or equal to about 90 nm, less than or equal to about 80 nm, less than or equal to about 70 nm, less than or equal to about 60 nm, less than or equal to about 55 nm, or less than or equal to about 50 nm, for example, about 20 nm to about 60 nm, about 30 nm to about 60 nm, or about 40 nm to about 60 nm.

[0076] When the average thickness of the electron transport layer **120** is less than about 20 nm, voids, cracks, and the like of the electron transport layer **120** may be increased and the device characteristics may be deteriorated, and it may be difficult to meet, e.g., achieve, a carrier balance with other constituent elements of the electroluminescent device.

[0077] On the other hand, when the average thickness of the electron transport layer **120** is greater than about 100 nm, electrons may be supplied to the emission layer **140** too fast, in too great a quantity, or a combination thereof compared with holes, and electrons may meet holes on the interface between the emission layer **140** and the hole transport layer **150** to cause interfacial light emission or may move to the hole transport layer **150**, the hole injection layer **160**, or a combination thereof to be quenched.

[0078] In an embodiment, the electron transport layer **120** may include inorganic oxide particles **121**. For example, the electron transport layer **120** may include a cluster layer composed of the inorganic oxide particles **121**.

[0079] In an embodiment, the inorganic oxide particles **121** may be composed of materials having electron transporting properties and thus the inorganic oxide particles **121** may have electron transporting properties. The inorganic oxide particles **121** according to an embodiment may be, for example, oxides including zinc, titanium, zirconium, tin, tungsten, tantalum, magnesium, gallium, sodium, copper, silver, or a combination thereof and may include, for example, ZnO, TiO₂, ZrO₂, SnO₂, WO₃, Ta₂O₃, or a combination thereof, but are not limited thereto.

[0080] The inorganic oxide particles **121** according to an embodiment may have dispersibility with respect to, e.g., be dispersible in, a polar solvent. The dispersibility of the inorganic oxide particles **121** may be caused by the hydroxyl group (—OH) on the surface of the inorganic oxide particles **121** at room temperature. For example, ZnO particles may include a large numbers of hydroxyl groups (—OH) on the surface at room temperature. Therefore, when the ZnO particles are introduced into a polar solvent such as water or ethanol at room temperature, the ZnO particles may be controlled to be dispersed evenly in the polar solvent without being agglomerated by a relatively simple physical treatment such as stirring.

[0081] Accordingly, it may be relatively easy to form a cluster layer composed of the inorganic oxide particles **121** by applying a solution in which the inorganic oxide particles **121** are dispersed in a polar solvent on the first electrode **110** and then drying the solution. In addition, the cluster layer formed thereon may have a relatively uniform distribution of the inorganic oxide particles **121** without agglomerating at a specific portion.

[0082] On the other hand, an average particle diameter of the inorganic oxide particles **121** according to an embodiment may be, for example, less than or equal to about 70 nm, less than or equal to about 60 nm, less than or equal to about 50 nm, less than or equal to about 40 nm, less than or equal to about 30 nm, less than or equal to about 20 nm, or less

than or equal to about 10 nm, and, for example, greater than or equal to about 1 nm, greater than or equal to about 2 nm, greater than or equal to about 3 nm, greater than or equal to about 4 nm, or greater than or equal to about 5 nm.

[0083] When the average particle diameter of the inorganic oxide particles **121** is within the above ranges, the cluster layer composed of the inorganic oxide particles **121** may exhibit excellent electron transporting properties.

[0084] In an embodiment, the electron transport layer **120** may include a metal-organic compound or a thermal decomposition product thereof having solubility with respect to, e.g., being soluble in, a non-polar solvent.

[0085] The metal-organic compound may be a metal salt having an organic group and may be, for example, a composite of a metal cation and an organic anion. The metal-organic compound has electron transporting properties like the above-mentioned inorganic oxide particles **121** but may have solubility with respect to a non-polar solvent, unlike the inorganic oxide particles **121**.

[0086] In an embodiment, the metal-organic compound may have the same or a similar level of electron transporting properties compared with the inorganic oxide particles **121**. The metal in the metal-organic compound may be a metal of Zn, Ti, Sn, W, Ta, Mg, Ga, Na, Cu, Ag, or a combination thereof.

[0087] On the other hand, the electron mobility and energy level of the metal-organic compound may vary depending on the metal, organic compound, or a combination thereof, but the electron mobility, the energy level, or a combination thereof may be the same as or similar to those of the inorganic oxide particles **121**.

[0088] For example, the metal in the metal-organic compound may be the same as the metal in the inorganic oxide particles **121**. For example, the inorganic oxide particles **121** may be metal oxide particles, and the metal element included in the metal oxide particles and the metal element contained in the metal-organic compound may be the same each other. In this case, it may be relatively easy to control the energy level, the electron mobility, or a combination thereof of the electron transport layer **120** to the same or a similar level.

[0089] However, an embodiment is not necessarily limited thereto, and the metal in the inorganic oxide particles **121** and the metal of the metal-organic compound may be different from each other in consideration of a charge carrier balances between the respective constituent elements of the electroluminescent element **10**.

[0090] In an embodiment, the organic compound in the metal-organic compound imparts solubility with respect to the non-polar solvent to the metal-organic compound. The organic compound may include an oleate-based compound, an amine-based compound, or a combination thereof. For example, the organic compound may be an oleate-based compound. However, an embodiment is not limited thereto, and the organic compound may include an oleate-based compound, an amine-based compound, a combination thereof, or at least other organic compounds that are different from the oleate-based compound or the amine-based compound.

[0091] In addition, examples of the non-polar solvent for dissolving the metal-organic compound may be a C6 to C20 linear, branched, or cyclic aliphatic hydrocarbon, C6 to C20 aromatic hydrocarbon, methylene chloride, ethyl acetate, or a combination thereof. The C6 to C20 linear, branched, or

cyclic aliphatic hydrocarbon may contain one or more unsaturated groups, but is not aromatic. Heteroatoms may or may not be present in the aliphatic or aromatic hydrocarbons, and are only present provided that the aliphatic or aromatic hydrocarbons are nonpolar.

[0092] When the organic compound in the metal-organic compound according to an embodiment is as disclosed above, a solution containing a metal-organic compound in a non-polar solvent may be applied to the cluster layer and then dried to form an electron transport layer **120** in a relatively simple manner.

[0093] Specifically, since the above-described cluster layer is produced using a polar solvent, when the metal-organic compound having solubility with respect to a polar solvent is used, the cluster layer may be damaged by the polar solvent. However, since the metal-organic compound according to an embodiment uses a non-polar solvent having chemical characteristics different from those of the inorganic oxide particles **121** damage to the surface of the cluster layer may be minimized when the metal-organic compound is applied on the cluster layer.

[0094] The thermal decomposition product of the metal-organic compound may refer to a product obtained by thermally decomposing a solution including the metal-organic compound in a process of coating and drying at a predetermined temperature. The thermal decomposition product of the metal-organic compound may include a metal, metal oxide, an organic compound, or a combination thereof.

[0095] Specifically, the thermal decomposition product may include a metal of Zn, Ti, Sn, W, Ta, Mg, Ga, Na, Cu, Ag, or a combination thereof, or oxides thereof, and carbon compounds.

[0096] The carbon compound may be a product in which the organic compound in the metal-organic compound, specifically, the oleate compound, the amine compound, and other organic compounds are separated from the metal by the thermal decomposition of the metal-organic compound, or a derivative thereof. The thermal decomposition product may be chemically bound to the surface of the inorganic oxide particles **121**.

[0097] The carbon compound may have solubility with respect to a non-polar solvent.

[0098] When the metal-organic compound or the thermal decomposition product thereof are included together with the inorganic oxide particles **121** as in the embodiment, there is a difference in an energy level change compared with the case where the inorganic oxide particles **121** are doped with metal.

[0099] Specifically, when Mg is used as a metal in the metal-organic compound and ZnO particles are used as the inorganic oxide particles **121** the electron transport layer **120** in which the pure Mg-organic compound or the thermal decomposition product thereof and the ZnO particles are mixed has slightly reduced lowest unoccupied molecular orbital (LUMO) energy and highest occupied molecular orbital (HOMO) energy levels compared with the electron transport layer including the ZnO particles alone. On the other hand, ZnMgO in which ZnO is doped with Mg may exhibit slightly increased LUMO and HOMO energy levels compared with the electron transport layer including ZnO particles alone.

[0100] In an embodiment, amounts of the metal-organic compound may be changed variously by regarding the

relationship between the above-described energy level, electron mobility. The amounts of the metal-organic compound may be variously adjusted in consideration of, for example, the organic compound bonding with the metal, the inorganic oxide particles **121** thicknesses of the electron transport layer **120**, and the like.

[0101] Referring to FIGS. **2** to **4**, the electron transport layer **120** in the electroluminescent devices **10**, **10'**, and **10''** may include a first layer including a cluster layer composed of the inorganic oxide particles **121**. In this case, the metal-organic compound or the thermal decomposition product thereof may be disposed at various positions between the first layer **124** and the emission layer **140**.

[0102] The average thickness of the first layer **124** may be changed in consideration of average particle diameters and materials of the inorganic oxide particles **121** and charge carrier balances between the emission layer **140**, the hole transport layer **150**, or a combination thereof, the hole injection layer **160**, and the like. However, the average thickness of the first layer **124** may be, for example, less than or equal to about 60 nm, less than or equal to about 50 nm, less than or equal to about 40 nm, less than or equal to about 35 nm, or less than or equal to about 30 nm, and, for example, greater than or equal to about 20 nm, greater than or equal to about 25 nm, or greater than or equal to about 30 nm.

[0103] When the average thickness of the first layer **124** satisfies the above ranges, the first layer **124** may exhibit excellent electron transporting properties.

[0104] Referring to FIG. **2**, a metal-organic compound or a thermal decomposition product thereof **122** in the electroluminescent device **10** directly contacts the surface of the first layer **124** facing the emission layer **140** and also may fill an empty space on the surface.

[0105] Specifically, with reference to the surface of the electron transport layer **120** facing the emission layer **140**, the surface may include a first region in which the inorganic oxide particles **121** is present and a second region in which the metal-organic compound or the thermal decomposition product thereof **122** filling the empty space among the neighboring inorganic oxide particles **121** is present.

[0106] On the surface of the electron transport layer **120** facing the emission layer **140**, the inorganic oxide particles **121** may be mixed with the metal-organic compound or the thermal decomposition product thereof **122**.

[0107] Accordingly, as for the electroluminescent device **10** according to FIG. **2**, the electron transport layer **120** may be a composite layer including the first layer **124** including the inorganic oxide particles **121** and a layer including the metal-organic compound or the thermal decomposition product thereof **122** and filling an empty space on the surface of the first layer **124** facing an emission layer, as described above.

[0108] On the other hand, referring to FIG. **3**, an electroluminescent device **10'** may further include a second layer **126** having a predetermined thickness between the emission layer **140** and the first layer **124** unlike the electroluminescent device **10** according to FIG. **2**, wherein the second layer **126** may include a metal-organic compound or a thermal decomposition product thereof. For example, the second layer **126** may be a layer formed of the metal-organic compound or the thermal decomposition product thereof.

[0109] Specifically, the surface of the electron transport layer **120** facing the emission layer **140** may be the surface

of the second layer **126**, and the inorganic oxide particles **121** may not be exposed to the surface but covered by the second layer **126** unlike the electroluminescent device **10** according to FIG. **2**. The surface of the second layer **126** facing the emission layer **140** may be relatively smooth compared with the surface of the first layer **124** contacting the second layer **126**. Accordingly, morphology of the electron transport layer **120** contacting the emission layer **140** may be improved.

[0110] As for the electroluminescent device **10'** of FIG. **3** like the electroluminescent device **10** of FIG. **2**, the surface of the first layer **124** directly contacts the metal-organic compound or the thermal decomposition product thereof, which may fill an empty space on the surface of the first layer **124**.

[0111] The second layer **126** according to an embodiment has a thickness enough to at least cover the surface of the first layer **124** contacting itself and not to expose the inorganic oxide particles **121** toward the emission layer **140**, as described above. On the other hand, the second layer **126** may be formed to be thicker than a desired thickness in consideration of interaction with a solution for forming the emission layer **140** during formation of the emission layer **140** which will be described later.

[0112] In an embodiment, the second layer **126** may have a thinner average thickness than that of the first layer **120** in consideration of all the above conditions, for example, an average thickness of greater than or equal to about 2 nm, greater than or equal to about 3 nm, greater than or equal to about 4 nm, greater than or equal to about 5 nm, or greater than or equal to about 10 nm, and, for example, less than or equal to about 15 nm, for example, in a range of about 3 nm to about 15 nm, for example, in a range of about 5 nm to about 15 nm, for example, in a range of about 7 nm to about 15 nm, or for example, in a range of about 10 nm to about 15 nm.

[0113] When the second layer **126** has an average thickness of less than about 2 nm, the thickness of the second layer **126** may be decreased by a non-polar solvent during formation of the emission layer **140** which will be described later, and the inorganic oxide particles **121** may be exposed. On the other hand, when the second layer **126** has an average thickness of greater than about 15 nm, a charge carrier balance of the whole electroluminescent device may be deteriorated.

[0114] In the electroluminescent devices **10** and **10'** according to FIGS. **2** and **3**, the empty space on the surface of the first layer **124** may be changed depending on an average particle diameter of the inorganic oxide particles **121** the thickness of the first layer **124**, and the like but inevitably formed, since the first layer **124** is a cluster layer formed of the inorganic oxide particles **121**. The empty space includes a void, a crack, or the like among the inorganic oxide particles **121**.

[0115] The empty space may function as a leakage path of electrons during operation of a device and may not be completely removed, though the first layer **124** may be formed by using inorganic oxide having excellent dispersibility regarding, e.g., in, a polar solvent.

[0116] However, in the electroluminescent devices **10** and **10'** of FIGS. **2** and **3**, the empty space of the first layer **124** may not only be filled with a metal-organic compound or a thermal decomposition product thereof, but also the surface

of the first layer **124** may be covered by the second layer **126** as shown in the electroluminescent device **10'** of FIG. 3.

[0117] In other words, as for the electroluminescent devices **10** and **10'** of FIGS. 2 and 3, a leakage path of an electron transport layer may be reduced by filling the space of the first layer **124** with the metal-organic compound or the thermal decomposition product thereof.

[0118] However, an embodiment is not necessarily limited thereto. For example, as for an electroluminescent device **10''** of FIG. 4, a first layer **124'** may include an organic material matrix filled among the, e.g., in between, neighboring inorganic oxide particles **121** unlike the cluster layer of the electroluminescent devices **10** and **10'** of FIGS. 2 and 3. Herein, the organic material matrix may include an organic material of a monomer, an oligomer, a polymer, or a combination thereof, wherein the organic material may be different from the metal-organic compound or the thermal decomposition product thereof.

[0119] For example, the organic material matrix may be a binder. In other words, the first layer **124'** may be a mixed layer of the inorganic oxide particles **121** and an organic material functioning as a binder. The organic material matrix may include various suitable organic materials without being particularly limited, provided that the organic material is different from the metal-organic compound or the thermal decomposition product thereof and functions as a binder.

[0120] On the other hand, the second layer **126'** may not fill an empty space inside the first layer **124'** but cover the first layer **124'**, and the surface of the first layer **124'** may not be exposed to the emission layer **140**. Herein, morphology of the surface of the first layer **124'** may be improved by covering the surface of the first layer **124'** with the second layer **126'**, through which a leakage current of an electron transport layer may be reduced.

[0121] In an embodiment, the electroluminescent devices **10'** and **10''** according to FIGS. 3 and 4 may have an equal or almost similar energy level between the first layers **124** and **124'** and the second layers **126** and **126'**. For example, when the same metal is used for the first layers **124** and **124'** and the second layers **126** and **126'**, a LUMO energy level of the second layers **126** and **126'** may be subtly increased by an organic compound and the like compared with that of the first layers **124** and **124'**.

[0122] However, a LUMO energy level difference between the second layers **126** and **126'** and the first layers **124** and **124'** may be, for example, less than or equal to about 0.3 electronvolts (eV), less than or equal to about 0.2 eV, or less than or equal to about 0.1 eV and may be designed to be close to 0 eV by changing a metal and an organic compound used for an electron transport layer as described above.

[0123] On the other hand, an embodiment is not necessarily limited thereto, but the second layers **126** and **126'** and the first layers **124** and **124'** may be variously adjusted to have a LUMO energy level difference of, for example, greater than about 0.3 eV, for example, greater than or equal to about 0.4 eV, greater than or equal to about 0.5 eV, or, for example, in a range of about 0.3 eV to about 0.7 eV. However, thicknesses of the second layers **126** and **126'** and the like may be adjusted to minimize the second layers **126** and **126'** from working as an energy barrier.

[0124] On the other hand, between the electron transport layer **120** and the first electrode **110**, an electron injection

layer facilitating injection of electrons, a hole blocking layer blocking movement of holes, or a combination thereof may be further formed.

[0125] Each average thickness of the electron injection layer and the hole blocking layer may be appropriately selected. For example, an average thickness of each layer may be greater than or equal to about 1 nm and less than or equal to about 500 nm but is not limited thereto. The electron injection layer may be an organic layer formed by deposition and may be omitted in consideration of the thicknesses and materials of the electron transport layer **120**.

[0126] The electron injection layer may include, for example, 1,4,5,8-naphthalene-tetracarboxylic dianhydride (NTCDA), bathocuproine (BCP), tris[3-(3-pyridyl)-mesityl] borane (3TPYMB), LiF, Alq₃, Gaq₃, Inq₃, Znq₂, Zn(BTZ)₂, BeBq₂, ET204 (8-(4-(4,6-di(naphthalen-2-yl)-1,3,5-triazin-2-yl)phenyl)quinolone), 8-hydroxyquinolino lithium (Liq), an n-type metal oxide (e.g., ZnO, HfO₂, etc.), or a combination thereof, but is not limited thereto.

[0127] The hole blocking layer may include, for example, 1,4,5,8-naphthalene-tetracarboxylic dianhydride (NTCDA), bathocuproine (BCP), tris[3-(3-pyridyl)-mesityl] borane (3TPYMB), LiF, Alq₃, Gaq₃, Inq₃, Znq₂, Zn(BTZ)₂, BeBq₂, or a combination thereof, but is not limited thereto. The hole blocking layer may be omitted in consideration of the thicknesses, materials, and the like of other constituent elements in the electroluminescent device **10**.

[0128] The emission layer **140** may be disposed between the electron transport layer **120** and the hole transport layer **150**. The emission layer **140** may be in contact with the electron transport layer **120** and may include at least two light emitting particles.

[0129] The emission layer **140** is a site to which electrons and holes are transported by a current supplied from the first electrode **110** and the second electrode **170**. The electrons and holes are combined in the emission layer **140** to generate excitons, and the generated excitons are transitioned from an excited state to a ground state to emit light in a wavelength corresponding to a size of the light emitting particles **141**.

[0130] On the other hand, the emission layer **140** may emit light in a predetermined wavelength region. The predetermined wavelength region belongs to a visible light region, for example, one of a first wavelength region of about 380 nm to about 488 nm, a second wavelength region of about 490 nm to 510 nm, a third wavelength region of greater than 510 nm to about 580 nm, a fourth wavelength region of about 582 nm to about 600 nm, and a fifth wavelength region of about 620 nm to about 680 nm.

[0131] In an embodiment, the light emitting particles **141** may include quantum dots. That is, all of the light emitting particles **141** may be quantum dots. One of the light emitting particles **141** may be formed of quantum dots, and another of the light emitting particles **141** may be a different light emitting body distinguished from the quantum dot, for example, a commercially available phosphor.

[0132] The quantum dots have a discontinuous energy band gap by the quantum confinement effect so as to convert incident light to light having a predetermined wavelength and to radiate the same. That is, when the light emitting particles **141** are composed of quantum dots, the emission layer **140** may generate light having excellent color reproducibility and color purity.

[0133] In an embodiment, a material of the quantum dots is not particularly limited and the quantum dots **3** may be

commercially available. For example, the light emitting particles **141** according to an embodiment may be quantum dots including a Group II-VI compound that does not include Cd, a Group III-V compound, a Group IV-VI compound, a Group IV element or compound, a Group compound, a Group I-II-IV-VI compound that does not include Cd, or a combination thereof. That is, the light emitting particles **141** according to an embodiment may be non-cadmium-based quantum dots. Like this, when the light emitting particles **141** are formed of non-cadmium-cadmium-based materials, the light emitting particles **141** may have little or no toxicity compared with a conventional cadmium-based quantum dots and thus are not dangerous and environmentally-friendly.

[0134] The Group II-VI compound may be a binary element compound of ZnS, ZnSe, ZnTe, ZnO, HgS, HgSe, HgTe, MgSe, MgS, or a combination thereof; a ternary element compound of ZnSeS, ZnSeTe, ZnSTe, HgSeS, HgSeTe, HgSTe, HgZnS, HgZnSe, HgZnTe, MgZnSe, MgZnS, or a combination thereof;

[0135] or a quaternary element compound of ZnSeSTe, HgZnTeS, HgZnSeS, HgZnSeTe, HgZnSTe, or a combination thereof. The Group II-VI compound may further include a Group III metal.

[0136] The Group III-V compound may be a binary element compound of GaN, GaP, GaAs, GaSb, AlN, AlP, AlAs, AlSb, InN, InP, InAs, InSb, or a combination thereof; a ternary element compound of GaNP, GaNAs, GaNSb, GaPAs, GaPSb, AINP, AINAs, AINSb, AIPAs, AIPs, InNP, InNAs, InNSb, InPAs, InPSb, InZnP, or a combination thereof; or a quaternary element compound of GaAlNP, GaAlNAs, GaAlNSb, GaAlPAs, GaAlPSb, GaInNP, GaInNAs, GaInNSb, GaInPAs, GaInPSb, InAlNP, InAlNAs, InAlNSb, InAlPAs, InAlPSb, or a combination thereof. The Group III-V compound may further include a Group II metal (InZnP).

[0137] The Group IV-VI compound may be a binary element compound of SnS, SnSe, SnTe, PbS, PbSe, PbTe, or a combination thereof; a ternary element compound of SnSeS, SnSeTe, SnSTe, PbSeS, PbSeTe, PbSTe, SnPbS, SnPbSe, SnPbTe, or a combination thereof; or a quaternary element compound of SnPbSSe, SnPbSeTe, SnPbSTe, or a combination thereof. Examples of the Group I-III-VI compound may be CuInSe₂, CuInS₂, CuInGaSe, or CuInGaS, but are not limited thereto. Examples of the Group I-II-IV-VI compound may be CuZnSnSe or CuZnSnS, but are not limited thereto. Examples of the Group IV compound may be a single substance of Si, Ge, or a combination thereof; or a binary element compound of SiC, SiGe, or a combination thereof.

[0138] The binary element compound, the ternary element compound or the quaternary element compound respectively exist in a uniform concentration in the particle or in partially different concentrations in the same particle.

[0139] According to an embodiment, the quantum dot may have a core-shell structure including one semiconductor nanocrystal core and another semiconductor nanocrystal shell surrounding the core. The core and the shell may have a concentration gradient wherein the concentration of the element(s) of the shell decreases in a direction from an outermost surface of the quantum dot toward the core. In addition, the quantum dot may have one semiconductor nanocrystal core and multi-shells surrounding the core. Herein, the multi-layered shell structure has a structure of

two or more shells and each layer may have a single composition or an alloy or may have a concentration gradient.

[0140] In an embodiment, the light emitting particles may have a core-shell structure. When the light emitting particles have a core-shell structure, a material composition of the shell has a larger energy bandgap than that of the core, which may exhibit an effective quantum confinement effect. However, the embodiment is not limited thereto. Meanwhile, in the multi-layered shell, a shell that is outside of the core may have a higher energy bandgap than a shell that is near to the core and quantum dots may have an ultraviolet (UV) to infrared wavelength ranges.

[0141] The quantum dot may have quantum efficiency of greater than or equal to about 10%, for example, greater than or equal to about 20%, greater than or equal to about 30%, greater than or equal to about 40%, greater than or equal to about 50%, greater than or equal to about 60%, greater than or equal to about 70%, greater than or equal to about 90%, or 100%.

[0142] In a display, the quantum dot may have a relatively narrow spectrum so as to improve color purity or color reproducibility. The quantum dot may have, for example, a full width at half maximum (FWHM) of wavelength spectrum of less than or equal to about 45 nm, less than or equal to about 40 nm, or less than or equal to or about 30 nm. Within the ranges, color purity or color reproducibility of a device may be improved.

[0143] The quantum dot may have a particle diameter (the longest diameter for a non-spherically shaped particle) of about 1 nm to about 100 nm). For example, the quantum dot may have a particle diameter of about 1 nm to about 20 nm, for example, about 2 nm (or about 3 nm) to about 15 nm.

[0144] In addition, a shape of the quantum dot may be any suitable shape and thus may not be particularly limited. For example, the quantum dot may have a spherical, oval, tetrahedral, pyramidal, cuboctahedral, cylindrical, polyhedral, multi-armed, or cube nanoparticle, nanotube, nanowire, nanofiber, nanosheet, or a combination thereof. The quantum dot may have any suitable cross-sectional shape.

[0145] The quantum dot may be commercially available or may be synthesized in any suitable method. For example, several nano-sized quantum dots may be synthesized according to a wet chemical process. In the wet chemical process, precursors react in an organic solvent to grow crystal particles, and the organic solvent or a ligand compound may coordinate, e.g., become bound to, the surface of the quantum dot, controlling the growth of the crystal. Examples of the organic solvent and the ligand compound may be readily determined by one skilled in the art. The organic solvent coordinated on the surface of the quantum dot may affect stability of a device, and thus residues that are not coordinated on the surface of the nanocrystals may be removed by pouring the organic solvent including the crystal in excess non-solvent and centrifuging the resulting mixture. Examples of the non-solvent may be acetone, ethanol, methanol, or the like, but are not limited thereto. After the removal of residues, the amount of ligand compounds, organic solvents, or a combination thereof which are coordinated on the surface of the quantum dot may be less than or equal to about 50% by weight, for example, less than or equal to about 30 wt %, less than or equal to about 20 wt %, or less than or equal to about 10 wt % based on a weight of the quantum dot.

[0146] A hydrophobic organic ligand having a hydrophobic moiety may be bound to the surface of the light emitting particle. In an embodiment, the hydrophobic organic ligand may include RCOOH, RNH₂, R₂NH, R₃N, RSH, R₃PO, R₃P, ROH, RCOOR', RPO(OH)₂, R₂POOH (wherein, R and R' are independently a C5 to C24 alkyl group, a C5 to C24 alkenyl group, a C5 to C20 alicyclic group, or a C6 to C20 aryl group), a polymeric organic ligand compound, or a combination thereof. For example, the hydrophobic organic ligand may be oleic acid, palmitic acid, myristic acid, stearic acid, or a combination thereof. The hydrophobic organic ligand may be an organic ligand having a mono-functional group, and the functional group may be chemically bound to the surface of the quantum dot.

[0147] When the hydrophobic organic ligand is attached to the surface of the light emitting particles, according to an embodiment, both of the light emitting body particles and the light emitting layer as a whole may have, e.g., exhibit, hydrophobicity. If the emissive layer 140 has, e.g., exhibits, hydrophobicity, the emissive layer 140 may be vulnerable to a non-polar solvent. That is, when the emission layer 140 and the non-polar solvent are in contact with each other, the emission layer 140 may be damaged by the non-polar solvent and thus device characteristics may be deteriorated.

[0148] However, the electroluminescent device 10 according to an embodiment may include the aforementioned metal-organic compound or thermal decomposition product thereof between a cluster layer formed of the inorganic oxide particles 121 and the emission layer 140 as described above, wherein the metal-organic compound or the thermal decomposition product thereof may fill an empty space on the surface of the cluster layer and form a layer having a predetermined thickness between the cluster layer and the emission layer 140. Accordingly, when the emission layer 140, which is hydrophobic, is formed on the already-formed electron transport layer 120, the emission layer may be prevented from a damage by a non-polar solvent.

[0149] The hole transport layer 150 may be disposed between the emission layer 140 and the second electrode 170, between the hole injection layer 160 and the emission layer 140, or between the emission layer 140 and the second electrode 170 and between the hole injection layer 160 and the emission layer 140. The hole transport layer 150 may provide and transport holes into the emission layer 140. The hole transport layer 150 may be formed directly under the emission layer 140 and may directly contact the emission layer 140.

[0150] In an embodiment, the hole transport layer 150 may be formed of the p-type semiconductor material, or the material doped with a p-type dopant. For example, the hole transport layer 150 may include a PEDOT (poly(3,4-ethylenedioxythiophene)) derivative, a PSS (poly(styrene sulfonate)) derivative, a poly-N-vinylcarbazole (PVK) derivative, a bicarbazole derivative, a polyphenylenevinylene derivative, a poly p-phenylene vinylene (PPV) derivative, a poly(meth)acrylate derivative, a poly(9,9-octylfluorene) derivative, a poly(spiro-fluorene) derivative, TCTA (tris(4-carbazol-9-yl phenyl)amine), TPD (N,N'-diphenyl-N,N'-bis(3-methylphenyl)-(1,1'-biphenyl)-4,4'-diamine), NPB (N,N'-di(naphthalen-1-yl)-N,N'-diphenyl-benzidine), m-MTDATA (tris(3-methylphenylphenylamino)-triphenylamine), TFB (poly[(9,9-dioctylfluorenyl-2,7-diyl-co(4,4'-(N-4-butylphenyl)diphenylamine)]), PFB (poly(9,9-dioctylfluorene)-co-N,N-diphenyl-N,N-di-(p-butylphenyl)-1,4-

diaminobenzene), poly-TPD, a metal oxide such as NiO and MoO₃, or a combination thereof, but is not limited thereto.

[0151] For example, the hole transport layer 150 may include TCTA and at least one of the compounds represented by Chemical Formula 1 to Chemical Formula 9 but is not limited thereto.

Chemical Formula 1

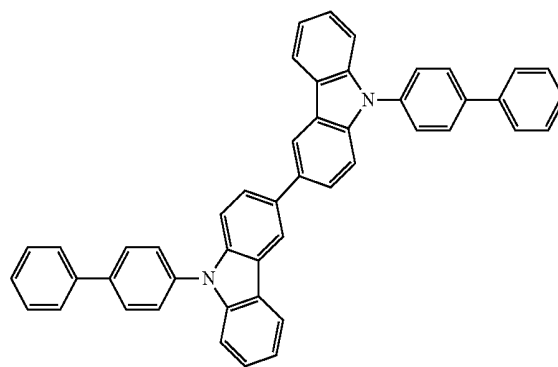

Chemical Formula 2

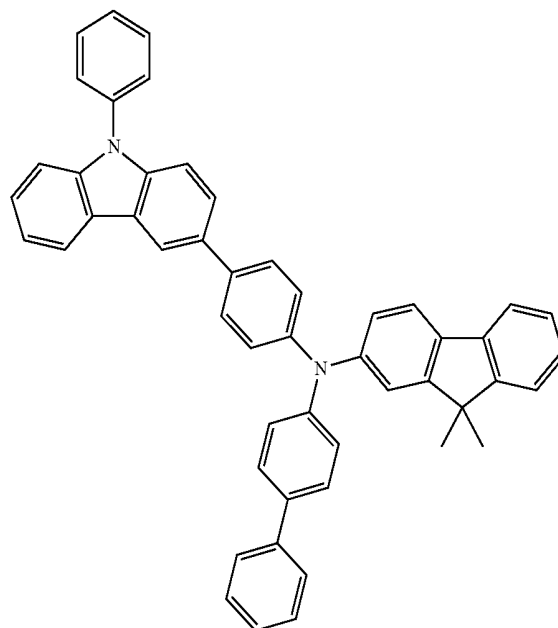

Chemical Formula 3

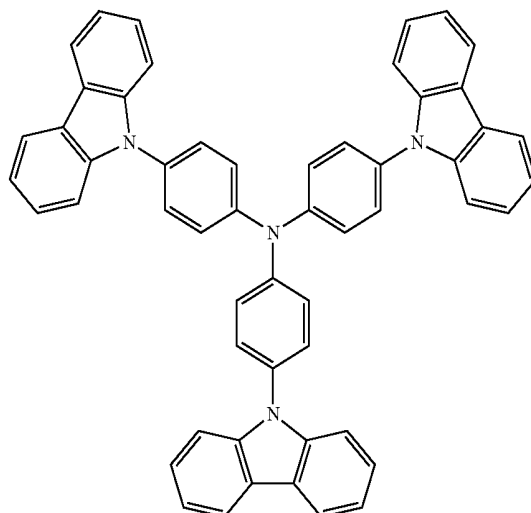

-continued

Chemical Formula 4

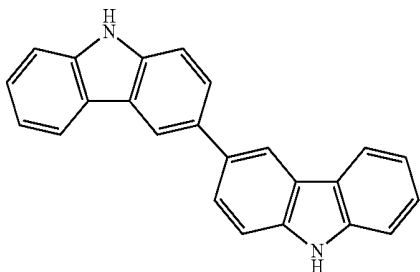

Chemical Formula 5

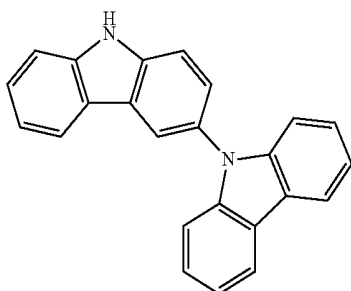

Chemical Formula 6

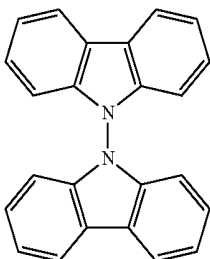

Chemical Formula 7

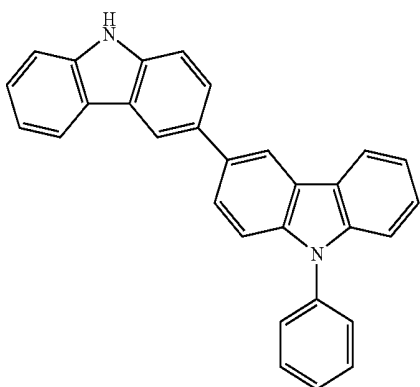

Chemical Formula 8

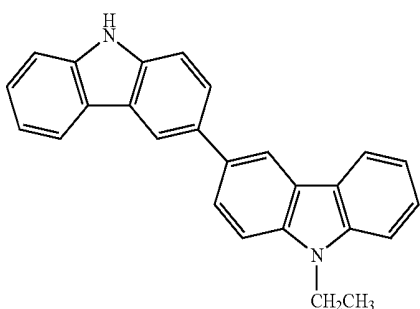

-continued

Chemical Formula 9

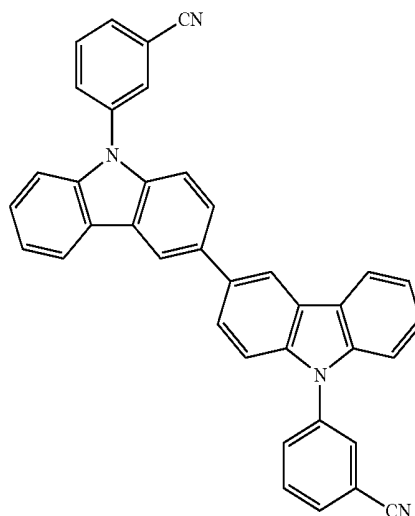

[0152] The hole transport layer **150** may be formed in a wet coating method such as spin coating and the like. In this way, the hole transport layer **150** may be formed on the emission layer **140** in a relatively simple method. Furthermore, when the emission layer **140** has, e.g., exhibits, hydrophobicity, a polar solvent may be selected as a solvent used for forming the hole transport layer **150** and damage of the emission layer **140** may be minimized.

[0153] For example, a polymer film such as PPV may be obtained by spin coating a precursor solution including a PPV precursor polymer and a polar solvent (e.g., water, methanol, ethanol, etc.) on the emission layer **140**, thermally treating it, for example, under an inert gas atmosphere of N₂ or vacuum at a curing temperature of about 250° C. to about 300° C. for 3 hours to obtain a hole transport layer **150** composed of the PPV thin film.

[0154] The hole injection layer **160** may be disposed between the hole transport layer **150** and the second electrode **170**. The hole injection layer **160** may supply holes into the emission layer **140** together with the hole transport layer **150**. However, the hole injection layer **160** may be omitted in consideration of the thicknesses and materials of the hole transport layer **150**.

[0155] On the other hand, the hole injection layer **160** may be formed of a p-type semiconductor material, or a material doped with a p-type dopant like the hole transport layer **150**. For example, the hole injection layer **160** may include a PEDOT (poly (3,4-ethylenedioxythiophene)) derivative, a PSS[poly(styrene sulfonate)] derivative, a poly-N-vinylcarbazole (PVK) derivative, a polyphenylenevinylene derivative, a poly p-phenylene vinylene (PPV) derivative, a polymethacrylate derivative, a poly(9,9-octylfluorene) derivative, a poly(spiro-fluorene) derivative, TCTA (tris(4-carbazol-9-yl phenyl)amine), TPD (N,N'-diphenyl-N,N'-bis(3-methylphenyl)-(1,1'-biphenyl)-4,4'-diamine), NPB (N,N'-di(naphthalen-1-yl)-N,N'-diphenyl-benzidine), m-MTDATA (tris(3-methylphenyl-N-phenylamino)-triphenylamine), TFB (poly[(9,9-dioctylfluorenyl-2,7-diyl-co(4,4'-(N-4-butylphenyl)diphenylamine)]), PFB (poly(9,9-dioctylfluorene)-co-N,N-diphenyl-N,N-di-(p-butylphenyl)-1,4-diaminobenzene), poly-TPD, a metal oxide such as NiO and MoO₃, or a combination thereof, but is not limited thereto.

[0156] As described above, in the electroluminescent device 10 according to an embodiment, the electron transport layer 120 includes the inorganic oxide particles 121 and the metal-organic compound or the thermal decomposition product thereof. Accordingly, the electroluminescent device 10 according to an embodiment may minimize void spaces between the neighboring inorganic oxide particles using the metal-organic compound or the thermal decomposition product thereof. As a result, the electroluminescent device 10 according to an embodiment may improve the luminous efficiency of the device by decreasing the leakage current.

[0157] Hereinafter, a display device including the electroluminescent device 10 is described.

[0158] A display device according to an embodiment includes a substrate, a driving circuit formed on the substrate, and a first electroluminescent device, a second electroluminescent device, and a third electroluminescent device spaced apart from each other in a predetermined interval and disposed on the driving circuit.

[0159] The first to third electroluminescent devices have the same structure as the electroluminescent device 10 and but the wavelengths of the lights emitted from each quantum dots may be different from each other.

[0160] In an embodiment, the first electroluminescent device may be a red device emitting red light, the second electroluminescent device may be a green device emitting green light, and the third electroluminescent device may be a blue device emitting blue light. In other words, the first to third electroluminescent devices may be pixels expressing, e.g., emitting, red, green, and blue, respectively, in the display device.

[0161] However, an embodiment is not necessarily limited thereto, but the first to third electroluminescent devices may respectively express, e.g., emit, one of magenta, yellow, cyan, or may express, e.g., emit, other colors.

[0162] On the other hand, one of the first to third electroluminescent devices may be the electroluminescent device 10. In this case, the third electroluminescent device expressing, e.g., emitting, blue may be desirably the electroluminescent device 10.

[0163] In the display device according to an embodiment, a hole injection layer, a hole transport layer, an electron transport layer, an electron injection layer, and a hole blocking layer except an emission layer of each pixel may be integrated to form a common layer. However, an embodiment is not limited thereto. A hole injection layer, a hole transport layer, an electron transport layer, an electron injection layer, and a hole blocking layer may be independently formed in each pixel of the display device, or a hole injection layer, a hole transport layer, an electron transport layer, an electron injection layer, a hole blocking layer, or a combination thereof may form a common layer and remaining layers may form a separate independent layer.

[0164] The substrate may be a transparent insulating substrate or may include a ductile material. The substrate may include a glass or polymer material and the polymer material may be a material having a glass transition temperature (T_g) of greater than about 150° C. For example, the substrate may include a COC (cycloolefin copolymer) or COP (cycloolefin polymer) based material. The first to third electroluminescent devices may be formed on the substrate. That is, a substrate of the display device according to an embodiment provides a common layer.

[0165] The driving circuit is disposed on the substrate and is independently connected to each of the first to third electroluminescent devices. The driving circuit may include a scan line, a data line, a driving power source line, a common power source line, or a combination thereof, at least two thin film transistors (TFT) connected to the wire and corresponding to one organic light emitting diode, and at least one capacitor, or the like. The driving circuit may have a variety of suitable structures.

[0166] As described above, a display device according to an embodiment may decrease a leakage current and improve device characteristics, and thus excellent electroluminescence characteristics may be exhibited.

[0167] Hereinafter, the embodiments are illustrated in more detail with reference to examples. However, these examples are exemplary, and the present disclosure is not limited thereto.

EXAMPLE 1

[0168] An indium-tin-oxide (ITO) layer is deposited on a glass substrate, and a ZnO cluster layer having an average thickness of about 30 nanometers (nm) to 35 nm is formed thereon by spin-coating a composition for a first electron transport layer which is prepared by dispersing 3 millimoles (mmol) of ZnO particles having an average particle diameter of 4.5 nm in ethanol solvent at 4000 rpm for 40 seconds and then, drying the composition at 80° C. for 30 minutes.

[0169] Subsequently, on the ZnO cluster layer, 0.1 mmol of a zinc-oleate compound in which Zn and oleate are included in a mole ratio of 1:1 is dissolved in 1 milliliters (mL) of hexane, and then, the solution is spin-coated at 4000 revolutions per minute (rpm) for 40 seconds.

[0170] The spin-coated layer is washed by using hexane and then, dried at 80° C. for 30 minutes to remove the hexane to deduce crystallization of the zinc-oleate compound and thus form a layer including a zinc-oleate compound or a thermal decomposition product thereof on the ZnO cluster layer. The layer including the zinc-oleate compound or the thermal decomposition product thereof covers the upper surface of the ZnO cluster layer and has a thinner average thickness than that of the ZnO cluster layer.

[0171] Subsequently, on the layer including the zinc-oleate compound or the thermal decomposition product thereof, a blue emission layer having a thickness of 25 nm is formed by coating a composition for an emission layer, which is prepared by dispersing a blue quantum dot (a ZnSeTe/ZnSe/ZnS core-shell blue quantum dot) to which a hydrophobic organic ligand (oleic acid) is attached and a binder in octane, and then, drying the composition at 80° C. The blue quantum dot has a maximum light emitting wavelength in a range of 440 nm to 460 nm, a full width at half maximum (FWHM) in a range of 18 nm to 25 nm, and external quantum efficiency of greater than or equal to 85%.

[0172] After forming the blue emission layer, an electron transport layer has an average thickness (an average thickness sum of the ZnO cluster layer and the layer including the zinc-oleate compound or the thermal decomposition product thereof) in a range of about 35 nm to 45 nm.

[0173] Subsequently, on the blue emission layer, a tris(4-carbazol-9-yl phenyl)amine (TCTA) layer is formed by coating a composition for a hole transport layer, in which TCTA is dissolved in methanol, and then, heating the composition at a high temperature.

[0174] Then, a MoO₃ layer as a hole injection layer is formed by depositing MoO₃ on a TCTA layer.

[0175] On the MoO₃ layer, a silver (Ag) layer is deposited to manufacture an electroluminescent device (the ITO/ZnO cluster layer/the layer including the zinc-oleate compound or the thermal decomposition product thereof/the blue emission layer/TCTA/MoO₃/Ag) of Example 1.

EXAMPLE 2

[0176] An electroluminescent device (an ITO/ZnO cluster layer/a layer including a zinc-oleate compound or a thermal decomposition product thereof/a red emission layer/Chemical Formula 1/MoO₃/Ag) of Example 2 is manufactured according to the same method as Example 1 except that a red emission layer is formed by using a red quantum dot (InP) to which a hydrophobic organic ligand (oleic acid) is attached instead of the blue quantum dot (ZnSeTe/ZnSe/ZnS) to which a hydrophobic organic ligand (oleic acid) is attached, and a hole transport layer formed of a bicarbazole-based compound represented by Chemical Formula 1 is included instead of the TCTA layer.

COMPARATIVE EXAMPLE 1

[0177] An electroluminescent device (an ITO/ZnO cluster layer/a blue emission layer/TCTA/MoO₃/Ag) is manufactured according to the same method as Comparative Example 1 except that the blue emission layer is formed right on the ZnO cluster layer.

COMPARATIVE EXAMPLE 2

[0178] An electroluminescent device (an ITO/ZnO cluster layer/a layer including a zinc-acetate compound or a thermal decomposition product thereof/a blue emission layer/TCTA/MoO₃/Ag) is manufactured according to the same method as Example 1 except that a composition for a second electron transport layer is prepared by dissolving 0.1 mmol of a zinc-acetate compound including Zn and acetate in a mole ratio of 1:1 in 1 mL of ethanol, and a layer including a zinc-acetate compound or a thermal decomposition product thereof is formed instead of the layer including a zinc-oleate compound or a thermal decomposition product thereof.

COMPARATIVE EXAMPLE 3

[0179] An electroluminescent device (an ITO/ZnO cluster layer/a ZnCl₂/blue emission layer/TCTA/MoO₃/Ag) is manufactured according to the same method as Example 1 except that a ZnCl₂ layer is formed by using a composition for a second electron transport layer which is prepared by dissolving 0.1 mmol of ZnCl₂ in 1 mL of acetone, instead of the layer including a zinc-oleate compound or a thermal decomposition product thereof, and also, using acetone instead of the hexane for the washing.

COMPARATIVE EXAMPLE 4

[0180] An electroluminescent device (an ITO/ZnO cluster layer/a layer including a zincdiethyldithiocarbamate compound or a thermal decomposition product thereof/a blue emission layer/TCTA/MoO₃/Ag) is manufactured according to the same method as Example 1 except that a layer including a zinc-diethyldithiocarbamate compound or a thermal decomposition product thereof instead of the layer including a zinc-oleate compound or a thermal decomposi-

tion product thereof is formed by using a composition for a second electron transport layer prepared by dissolving 0.1 mmol of a zinc-diethyldithiocarbamate compound including Zn and diethyldithiocarbamate including in a mole ratio of 1:1 in chloroform (CHCl₃) and also, using chloroform instead of the hexane for the washing.

COMPARATIVE EXAMPLE 5

[0181] An electroluminescent device (an ITO/ZnO cluster layer/a red emission layer/Chemical Formula 1/MoO₃/Ag) is manufactured according to the same method as Example 2 except that the red emission layer is formed right on the ZnO cluster layer.

Evaluation 1: Comparison of Surface Images between Surfaces of ZnO Cluster Layer and ZnO Cluster Layer/Layer Including Zinc-oleate Compound or Thermal Decomposition Product

[0182] FIGS. 5 and 6 respectively show the upper surface of the ZnO cluster layer in Comparative Example 1 and the surface of the layer including a zinc-oleate compound or a thermal decomposition product thereof on the ZnO cluster layer in Example 1.

[0183] FIG. 5 shows a scanning electron microscopic (SEM) image of the surface of the ZnO cluster layer of Comparative Example 1, and FIG. 6 is a SEM image of the surface of a zinc-oleate or a thermal decomposition product layer thereof formed on the ZnO cluster layer of Example 1.

[0184] Referring to FIG. 5, the ZnO cluster layer of Comparative Example 1 has a first region (a relatively bright region) filled with ZnO particles and a second region (a black region) not filled with the ZnO particles but left as an empty space, as described above. This second region left as an empty space includes a void and/or a crack and may work as a leakage path during electron transportation of a device.

[0185] On the other hand, referring to FIG. 6, the layer including a zinc-oleate compound or a thermal decomposition product thereof of Example 1 may be formed to cover the ZnO cluster layer as well as partially and/or fully fill the empty space on the surface of the ZnO cluster layer. Accordingly, when the layer including a zinc-oleate compound or a thermal decomposition product thereof of the Examples is formed right on the ZnO cluster layer, the void and/or the crack in the ZnO cluster layer may be removed or minimized.

Evaluation 2: Device Characteristics of Electroluminescent Devices of the Examples and Comparative Examples

[0186] Relationships between voltage-current density and luminance-external quantum efficiency of the electroluminescent devices of Example 1 and Comparative Examples 1 to 4 are shown in FIGS. 7 to 8, respectively.

[0187] FIG. 7 is a voltage-current density curve of the electroluminescent devices of Example 1 and Comparative Examples 1 to 4. In FIG. 7, the change of the current density according to the voltage is represented by a log scale.

[0188] Referring to FIG. 7, an electroluminescent device having the electron transport layer (the layer including a ZnO cluster layer/zinc-oleate compound or a thermal decomposition product thereof) of Example 1 exhibits a current density increase at a voltage of less than or equal to about 2.5 V compared with the electroluminescent devices of the Comparative Examples and particularly, a stable current density increase effect compared with Comparative

Examples 1, and an excellent current density increase effect compared with Comparative Examples 3 to 4.

[0189] FIG. 8 is a luminance-external quantum efficiency (EQE) curve showing the electroluminescent devices of Example 1 and Comparative Examples 1 to 4.

[0190] Referring to FIG. 8, the electroluminescent device of Example 1 exhibits 1.8 times to 2.5 times higher maximum external quantum efficiency than those of the Comparative Examples. In addition, when external quantum efficiency is compared depending on a particular luminance, Example 1 exhibits about 1.4% of external quantum efficiency at 100 nits (candelas per square meter), Comparative Example 1 exhibits about 0.8% of external quantum efficiency at 100 nits, Comparative Examples 2 and 4 respectively show about 1.0% of external quantum efficiency at 100 nits, and Comparative Example 3 exhibits about 0% of external quantum efficiency at 100 nits.

[0191] In addition, as for external quantum efficiency at 500 nits, Example 1 exhibits about 2.4%, Comparative Example 1 exhibits about 1.4%, Comparative Example 2 exhibits about 1.5%, Comparative Example 3 exhibits 0%, and Comparative Example 4 exhibits about 0.9%, and as for external quantum efficiency at 1000 nits, Example 1 exhibits about 2.3%, Comparative Example 1 exhibits about 1.2%, Comparative Example 2 exhibits about 0.5%, and Comparative Examples 3 and 4 respectively show about 0%.

[0192] On the other hand, as for maximum luminance of each electroluminescent device, Example 1 exhibits about 1400 Cd/m², Comparative Example 1 exhibits about 1200 Cd/m², Comparative Example 2 exhibits about 1000 Cd/m², Comparative Example 3 exhibits about 24 Cd/m², and Comparative Example 4 exhibits about 740 Cd/m².

[0193] First, Comparative Example 3 exhibits deteriorated properties relative to the other Comparative Examples. While not wanting to be bound by theory, it is understood that the reason that Comparative Example 3 exhibits deteriorated properties relative to the other Comparative Examples is that when ZnCl₂ instead of the metal-organic compound is included as a compound for forming the electron transport layer, the ZnCl₂ layer on the ZnO cluster layer has equivalent or more voids and/or cracks than the ZnO cluster layer. Accordingly, when a second electron transport layer is formed by using not a metal-organic compound but an inorganic compound such as ZnCl₂ and the like, device characteristics are more difficult to realize.

[0194] On the other hand, Comparative Examples 2 to 4 using a polar solvent during formation of the layer including a metal-organic compound or a thermal decomposition product thereof show equivalent external quantum efficiency and/or maximum luminance (Comparative Example 2) to those of Comparative

[0195] Example 1 having only a ZnO cluster layer and much deteriorated external quantum efficiency and/or maximum luminance (Comparative Examples 3 and 4) compared with those of Comparative Example 1. Accordingly, while not wanting to be bound by theory, it is understood that when a metal-organic compound having solubility in a non-polar solvent is deposited using a polar solvent instead, the polar solvent may have an influence on the ZnO cluster layer.

[0196] In other words, Comparative Examples 2 to 4 fill a void and/or a crack of a ZnO cluster layer by using a metal-organic compound or a thermal decomposition product thereof similarly to Example 1 but with a polar solvent, which results in damage and the like on the ZnO cluster

layer by the polar solvent, and accordingly, the metal-organic compound or the thermal decomposition product thereof has no significant effect (Comparative Example 2) and rather exhibits deteriorated performance (Comparative Examples 3 and 4).

[0197] Accordingly, when a layer including a metal-organic compound or a thermal decomposition product thereof on a ZnO cluster layer is formed by using a metal-organic compound having solubility in a non-polar solvent, and a non-polar solvent is used, Example 1 exhibits excellent external quantum efficiency over about 100 nits to 1000 nits compared with Comparative Examples.

Evaluation 3: Life-span Characteristics of Electroluminescent Devices of the Examples and Comparative Examples

[0198] Life-span characteristics of the electroluminescent devices (blue) of Example 1 and Comparative Example 1 and life-span characteristics of the electroluminescent devices (red) of Example 2 and Comparative Example 5 are shown in FIGS. 9 to 10, respectively.

[0199] FIG. 9 shows life-span characteristics of the electroluminescent devices of Example 1 and Comparative Example 1 and FIG. 10 shows life-span characteristics of the electroluminescent devices of Example 2 and Comparative Example 5.

[0200] Referring to FIGS. 9 and 10, since Example 1 exhibits a luminance of 50% (T50) of about 1.5 hours, while Comparative Example 1 exhibits T50 of about 1 hour, Example 1 exhibits an about 1.5 times life-span improvement effect with a reference to that of a blue electroluminescent device. On the other hand, Example 2 exhibits T50 of about 67.7 hours, while Comparative Example 5 exhibits T50 of about 9.7 hours, and thus an about 7 times life-span improvement effect with a reference to a red electroluminescent device.

[0201] Accordingly, the electroluminescent devices of the Examples exhibit excellent life-span characteristics compared with the Comparative Examples, which did not include a layer of a metal-organic compound or a thermal decomposition product thereof. While not wanting to be bound by theory, it is understood that the reason the electroluminescent devices of the Examples exhibit excellent life-span characteristics compared with the Comparative Examples is that the layer of a metal-organic compound or a thermal decomposition product thereof makes possible a stable current injection into an electron transport layer and thus improves a charge carrier balance.

[0202] While this disclosure has been described in connection with what is presently considered to be practical example embodiments, it is to be understood that the invention is not limited to the disclosed embodiments. On the contrary, it is intended to cover various modifications and equivalent arrangements included within the spirit and scope of the appended claims.

<Description of Symbols>

10: electroluminescent device	100: substrate
110: first electrode	120: electron transport layer
121: inorganic oxide particle	124: first layer
126: second layer	140: emission layer

-continued

<Description of Symbols>	
141: light emitting particle	150: hole transport layer
160: hole injection layer	170: second electrode

What is claimed is:

1. An electroluminescent device, comprising a first electrode and a second electrode facing each other; an emission layer disposed between the first electrode and the second electrode, the emission layer comprising light emitting particles; an electron transport layer disposed between the first electrode and the emission layer; and a hole transport layer disposed between the second electrode and the emission layer, wherein the electron transport layer comprises inorganic oxide particles and a metal-organic compound, the metal-organic compound or a thermal decomposition product of the metal-organic compound being soluble in a non-polar solvent.
2. The electroluminescent device of claim 1, wherein the metal-organic compound comprises Zn, Ti, Sn, W, Ta, Mg, Ga, Na, Cu, Ag, or a combination thereof.
3. The electroluminescent device of claim 1, wherein the metal-organic compound comprises an oleate compound, an amine compound, or a combination thereof.
4. The electroluminescent device of claim 1, wherein the non-polar solvent comprises a C6 to C20 linear, branched, or cyclic aliphatic hydrocarbon, a C6 to C20 aromatic hydrocarbon, methylene chloride, ethyl acetate, or a combination thereof.
5. The electroluminescent device of claim 1, wherein the inorganic oxide particles comprise zinc, titanium, zirconium, tin, tungsten, tantalum, magnesium, gallium, sodium, copper, silver, or a combination thereof.
6. The electroluminescent device of claim 1, wherein the inorganic oxide particles are dispersible in a polar solvent.
7. The electroluminescent device of claim 1, wherein a surface of the electron transport layer facing the emission layer comprises
 - a first portion in which the inorganic oxide particles are disposed and
 - a second portion in which the metal-organic compound or the thermal decomposition product of the metal-organic compound is between neighboring inorganic oxide particles.
8. The electroluminescent device of claim 1, wherein the electron transport layer comprises
 - a first layer comprising the inorganic oxide particles and
 - a second layer comprising the metal-organic compound or the thermal decomposition product of the metal-organic compound.
9. The electroluminescent device of claim 8, wherein the second layer is disposed between the first layer and the emission layer.

10. The electroluminescent device of claim 8, wherein the first layer comprises a cluster layer comprising the inorganic oxide particles.

11. The electroluminescent device of claim 10, wherein a surface of the first layer facing the second layer comprises the metal-organic compound or the thermal decomposition product of the metal-organic compound.

12. The electroluminescent device of claim 8, wherein the first layer comprises an organic matrix filled in between neighboring inorganic oxide particles and the organic matrix comprises an organic material that is different from the metal-organic compound or the thermal decomposition product of the metal-organic compound.

13. The electroluminescent device of claim 8, wherein an average thickness of the second layer is less than an average thickness of the first layer.

14. The electroluminescent device of claim 1, wherein the inorganic oxide particles comprise metal oxide particles, and a metal in the metal oxide particles and a metal in the metal-organic compound are the same.

15. The electroluminescent device of claim 1, wherein an average thickness of the electron transport layer is about 20 nanometers to about 60 nanometers.

16. The electroluminescent device of claim 1, wherein the light emitting particles comprise quantum dots.

17. The electroluminescent device of claim 1, wherein the light emitting particles have a core-shell structure.

18. The electroluminescent device of claim 1, wherein the light emitting particles comprise a Group II-VI compound that does not comprise Cd, a Group III-V compound, a Group IV-VI compound, a Group IV element or compound, a Group V compound, a Group I-II-IV-VI compound that does not comprise Cd, or a combination thereof.

19. The electroluminescent device of claim 1, wherein a hydrophobic organic ligand is attached to a surface of the light emitting particles.

20. A display device comprising the electroluminescent device of claim 1.

21. A method of forming an electroluminescent device, the method comprising

disposing a first electrode and a second electrode facing each other;

disposing an emission layer between the first electrode and the second electrode, the emission layer comprising light emitting particles;

disposing an electron transport layer between the first electrode and the emission layer, the electron transport layer comprising

inorganic oxide particles, and

a metal-organic compound, the metal-organic compound or a thermal decomposition product of the metal-organic compound being soluble in a non-polar solvent; and

disposing a hole transport layer between the second electrode and the emission layer.

* * * * *

专利名称(译)	电致发光器件，其制造方法以及包括该电致发光器件的显示装置		
公开(公告)号	US20190288229A1	公开(公告)日	2019-09-19
申请号	US16/351654	申请日	2019-03-13
[标]申请(专利权)人(译)	三星电子株式会社		
申请(专利权)人(译)	SAMSUNG ELECTRONICS CO. , LTD.		
当前申请(专利权)人(译)	SAMSUNG ELECTRONICS CO. , LTD.		
[标]发明人	KIM SUNG WOO KIM CHAN SU KIM TAE HO JANG EUN JOO KIM JIN A KIM TAE HYUNG LEE JEONG HEE		
发明人	KIM, SUNG WOO KIM, CHAN SU KIM, TAE HO PARK, KUN SU JANG, EUN JOO KIM, JIN A KIM, TAE HYUNG LEE, JEONG HEE		
IPC分类号	H01L51/50 H01L51/00 H01L51/42		
CPC分类号	H01L51/4213 H01L51/5072 H01L51/0062 H01L51/5012 H01L51/5056 B82Y30/00 H01L51/502 H01L51/5076 H01L51/508 H01L51/56 H01L2251/301 H01L2251/303		
优先权	1020180029942 2018-03-14 KR 1020190028358 2019-03-12 KR		
外部链接	Espacenet USPTO		

摘要(译)

一种电致发光器件，其制造方法以及包括该电致发光器件的显示装置。电致发光器件包括彼此面对的第一电极和第二电极；发光层，设置在第一电极和第二电极之间，发光层包括发光颗粒；电子传输层，设置在第一电极和发光层之间；空穴传输层，设置在第二电极和发光层之间，其中电子传输层包括无机氧化物颗粒和金属有机化合物，金属有机化合物或金属有机化合物的热分解产物可溶于非极性溶剂。

